



Western
Reitturnier
American Quarter
Horses

**Sinsheim Open 2017
Aufgabenheft
also NRCHA approved**

*Zuschauer sind
herzlich willkommen!*



NRCHA
NATIONAL REINED COW HORSE ASSOCIATION

DEUTSCHE
QUARTER
HORSE
ASSOCIATION

AMERICAN
QUARTER
HORSE
ASSOCIATION

Sinsheim Open 2017



Approved Shows on Saturday & Sunday May 06. & 07. 2017:

Open Spectacular
Open Pre Derby
Open Bridle

Non Pro Bridle
Non Pro Bridle Ltd.
Non Pro Bridle Ltd. 5k

Judge: Bozo Rogers, USA

will be held in Sinsheim at



Teilnehmerliste Sinsheim Open

2	Brave Double Chex	Jung; Bernd H
3	Joe Black TB	Pressel; Stefanie
4	Dualin Rippy	Last; Gerhard
5	Diamond B Phoenix	Fabian; Viola
6	Seven X Peppy	Finzel; Nicole
7	BMS Mia Starlight	Bossert; Juergen
8	Cat Garrett	Wuest; Carl
9	Signed By Chex	Goetz; Katharina
10	Listos Lil Playgirl	Goetz; Katharina
11	High Ima Whiz Kid	Goetz; Achim
12	Nurse Wendy	Holm; Ute
13	Miss Little Pepto	Holm; Ute
14	Ima Poco Steeldust	Holm; Ute
15	Sweet Lil Jewl	Holm; Ute
16	Dry Cats Annie	Leible; Kevin
17	Haidas Cutter Lynx	Turge; Doerte
18	Amazing Sugar Star	Hildenbrand; Thomas
19	De Baviera Cimarron	Werdermann; Andreas
20	EH Oneof Lenasfinest	Resch; Gabriele
21	Cromed Gold	Spitzenberger; Meiko
22	MTF Tuffy Tucker Chex	Braun; Ilona
23	Shooters Little Sun	Traub; Armin
24	Low Rider	Baumann; Sibylle
25	Tivos Lena	Vetter; Steffen
26	Brady Smoke Jo	Lorentz; Julie
27	Pepito	Lorentz; Claude
28	Eyota	Koebel; Patrick
29	Footworks Surprise	Krause; Lothar
30	Pocos Rebel Son	Weber; Karina
31	Tivos Poco Booker	Weber; Andre
32	LM Docs Cayenne	Maier; Miriam
33	Skips Hunting Hawk	Biesalski; Bettina
34	JH Champs Pine Girl	Wirkner; Ute
35	Lindas Jac For You	Zweers; Jan Roelof
36	Miss Genuine Whiz	Waesch; Jennifer
37	Smart Time Pepto	Oser; Sven
38	Gatlings Hot Cookie	Gembe; Ralph
39	Tarita Dual Spring	Stein; Masha
40	Redwhiteandblue Boon	Peter; Elena
41	Dr Starfish	Opitz; Rene
42	Just A Little Spat	Opitz; Rene
43	MK Lil Tronas Lass	Opitz; Rene
44	Rock Me Graygun	Oser; Sven
45	Flofefine Calbar	Hetzel; Alina
		Werdermann; Joschka
		Gerlinger; Bernhard

Teilnehmerliste Sinsheim Open

46	Mr Dual Skipp	Villar Lado; Maria
47	A Roosters Wrangler	Lepschi; Katrin
48	Smart Little Pick	Henny; Nina Judith
49	Chicago Train	Randecker; Dieter
50	GB Naomi Jac	Randecker; Johanna
51	Urano De Maripa	Heinen; Sandra
52	MCR Highguineoakey	Heinen; Clara Marie
53	Silent Little Lynx	Siegle; Rolf
54	Double Oak Lightning	Goette; Regina
55	Freckled Jay Bars	Utescheny; Gottfried
56	Us Hollywood Skeets	Schnepf; Frank
57	Miss Bueno San Tari	Harr; Anja
58	Little Lina RSK	Dittmeyer; Siegmund
59	Mas Qiero	Oser; Sven
60	Smart Little Theo	Bartmann; Katrin
61	PQH Spot On Chic	Bartmann; Maik
63	PQH Look Im Red	Pfeiffer; Uwe
64	ShinersSmartLasandro	Schemuth; Martin
65	Jacks Red Sunshine	Schemuth; Martin
66	MS Classy Mate	Ehrstein; Laurent
67	Tivios Prize	Sattler; Patrick
68	Justa Little Slipper	Bate; Sylvia G
69	Hollywoods BuckOlena	Sattler; Patrick
70	Tardys Red Peppy	Oberwegner; Sabine
71	Siouxinaddress	Bartmann; Maik
72	OT The Hot Stepper	Pressel; Jan
73	Jim Beam	Plattner; Benedikt
74	Haidas Little Sun	Schwan; Claudia



TOPSAIL WHIZARD

FOOTWORKS FINEST

HOLLYWOOD DUN IT

GREAT PINE

TOPSAIL WHIZ

STARRIN AS THE WHIZ



MULTIPLE BRONCE TROPHY WINNER USA

AQHA OPEN SUPERIOR REINING HORSE

RESERVE EUROPEAN CHAMPION REINING

DQHA SSA UND NRHA EINBEZAHLT

DECKTAXE IN 2017: EUR 1.000,--
TG ODER NATURSPRUNG

WWW.TOPSAIL-WHIZARD.DE

Als Hauptsponsor für den Gesamtsieger RHV Einsteiger auf dem Sinsheim Open 2017 möchten wir dem ROSENHOF herzlich danken!!!

Der Gewinner der Gesamtwertung RHV EINSTEIGER erhält einen Decksprung im Wert von 1.000,- € des Deckhengstes Topsail Whizard in Form eines Gutscheins, welcher direkt bei der Siegerehrung überreicht wird!

ZEITPLAN SINSHEIM OPEN 2017 **EINSTEIGER & JUGENDLICHE**

Hauptpreis der RHV Einsteiger ein Decksprung vom ROSENHOF – Topsail Whizard

Sa. 06. Mai 2016

Ranch Horse Event:

ROSENHOF Einsteiger & Jugendliche

Cow Horse Arena 30 x 60 m

Halle 20 x 40 m

08:30 – 09:00 h
09:00 – 11:30 h

Begehung Trail Parcours mit Richter (ohne Pferd)
Ranch Trail & Riding Einsteiger & Jugendl. (18+2)

12:10 – 12:45 h
12:45 – 12:55 h
12:55 – 13:30 h

Ranch Cutting **Einsteiger** (10) aus 2. Bunch direkt im Anschluss
(*Bunch Wechsel...*)
Ranch Cutting **Einsteiger & Jugendliche** (8+2) aus 1. Bunch

Mittagspause

13:50 – 14:20 h

*Cow Horse Dry Work Boxing class / Einsteiger
(class in class NRCHA Non Pro Ltd.) (9)*

14:30 – 15:30 h

Ranch Reining **Einsteiger & Jugendl.** (18+2)

(3 min. / 1 x Abziehen)

16:15 – 17:00 h

*Cow Horse Fence Work Boxing class/ Einsteiger
(class in class NRCHA Non Pro Ltd.) (9)*

17:15 – 17:30 h

Siegerehrung sämtlicher Cow Horse Prüfungen aller Verbände (Reining Arena)

17:30 – 17:35 h

Abziehen

17:35 – 18:25 h

Ranch Cow Work **Einsteiger & Jugendliche** (18+2) (2,5 min.)

18:35 – 19:15 h

Ranch Conformation **Einsteiger & Jugendliche** (18+2)

19:30 – 19:45 h

Siegerehrungen **Einsteiger & Jugendliche** (18+2)

19:45 h

Turnierende

Aufgrund der vielen Nennungen und dem knappen Zeitplan bitten wir ALLE Reiter darum bei den Prüfungen zügig ein- und wieder auszureiten! Vielen DANK!

Zeitplan Sinsheim Open 2017 Einsteiger final

Sponsoren des Turniers



De Futterlade

Futter und mehr... für Ihr Tier

Nicole Finzel

0152-53668628

nicole.finzel@gmx.de



ZEITPLAN SINSHEIM OPEN 2017

Fr. 05. Mai 2017

Paid Warm Up

17:00 – 17:15 h
 17:30 – 17:45 h
 18:00 – 18:15 h

Cow Horse Arena 30 x 80 m

Herd Work (Round Pen) (3)
 Fence Work (2)

Reining Arena 30 x 60 m

Reining Paid warm up (3) (a' 4,5 min.)

Sa. 06. Mai 2017

NRCHA-AQHA Event

06:30 – 07:25 h
 07:30 – 07:50 h
 07:50 – 08:10 h
 08:10 – 08:15 h
 08:15 – 08:35 h
 08:35 – 09:15 h
 09:15 Uhr

freies Abreiten...

...

...

Siegerehrung beider Reining Prüfungen

freies Abreiten...

DQHA/rasseoffen Reining Amateur (4)
 DQHA/rasseoffen Reining Open (4)

DQHA/rasseoffen Ranch Riding Open (5)
 DQHA/rasseoffen Ranch Riding Amateur (7)
Siegerehrung beider Ranch Riding Prüfungen

08:45 – 09:15 h
 09:15 – 10:50 h
 10:50 – 11:10 h
 11:10 – 11:20 h
 11:20 – 11:50 h
 11:50 – 12:00 h
 12:00 – 12:30 h

(settling herd ...)

AQHA/rasseoffen Cutting Open (8)
 AQHA/rasseoffen Cutting Amateur (5)
(settling herd ...)

Spectacular Open (7) herd work

NRCHA Pre-Derby Open Herd (3)

Siegerehrung Cutting Open & Amateur direkt im Anschluss in Reining Arena

Mittagspause

12:10 – 12:45 h
 12:45 – 12:55 h
 12:55 – 13:30 h

Ranch Cutting **Einsteiger (10)** aus 2. Bunch direkt im Anschluss
(Bunch Wechsel...)

Ranch Cutting **Einsteiger & Jugendliche (8+2)** aus 1. Bunch

12:30 – 13:45 h

Cow Horse Dry Work Open & Amateur (23)
/Non Pro Bridle ROSENHOF Preisgeld 250 € add.
class in class NRCHA/AQHA/rasseoffen/EWU-Quali / Open Jun. (5);
Spectacular (7); Amateur (8); Pre-Derby (3); (3,5 min. / lope in Pattern)

13:45 – 13:50 h

Abziehen

13:50 – 14:20 h

Cow Horse Dry Work Boxing class / Einsteiger
(class in class NRCHA Non Pro Ltd.) (9)

14:20 – 14:25 h

Abziehen

14:25 – 16:05 h

Cow Horse Fence Work Open & Amateur (23)
/Non Pro Bridle ROSENHOF Preisgeld 250 € add.
class in class NRCHA/AQHA/rasseoffen/EWU-Quali / Open Jun. (5);
Spectacular (7); Amateur (8); Pre-Derby (3);

16:10 – 16:15 h

Abziehen

16:15 – 17:00 h

Cow Horse Fence Work Boxing class/Einsteiger (9)

17:15 – 17:30 h

Siegerehrung sämtlicher Cow Horse Prüfungen
aller Verbände (Reining Arena) inkl.
Non Pro Bridle ROSENHOF mit 250 € add.

17:35 – 18:25 h

Ranch Cow Work **Einsteiger & Jugendliche** (18+2) (2,5 min.)

18:35 – 19:15 h

Ranch Conformation **Einsteiger & Jugendliche** (18+2)

19:30 – 19:45 h

Siegerehrungen **Einsteiger & Jugendliche** (18+2)

Sa. 07. Mai 2016

Ranch Horse Event:

Open – Amateur

Reining Arena 30 x 60 m

17:30 – 17:45 h

Abziehen

17:45 – 19:00 h

Ranch Reining Open (11) & Amateur (14)
(3 min. / 1 x Abziehen)

Aufgrund der vielen Nennungen und dem knappen Zeitplan bitten wir ALLE Reiter darum bei den Prüfungen zügig ein- und wieder auszureiten! Vielen DANK und VIEL SPASS!

ZEITPLAN SINSHEIM OPEN 2017

So. 07. Mai 2016

Ranch Horse Event:

Open – Amateur

Cow Horse Arena 30 x 80 m

Reining Arena 30 x 60 m

07:30 – 07:55 h
08:00 – 09:15 h
09:15 – 11:00 h
11:00 – 11:10 h
10:45 – 11:15 h
11:15 – 12:15 h
12:15 – 12:40 h
12:40 – 13:40 h
13:40 – 13:55 h

Begehung Trail mit Richter (ohne Pferd)
Ranch Horse Open Trail & Ranch Riding (11)
Ranch Horse Amateur Trail & Ranch Riding (14)
Siegerehrung Versatility Open/Amateur in Trail & Riding (Reining Arena)

(*settling herd...*)

1. Bunch Ranch Cutting Open (11) & Amateur (2)
(*settling herd...*)
2. Bunch Ranch Cutting Amateur (12)

Siegerehrung Versatility Open/Amateur in Ranch Cutting (Reining Arena)

Mittagspause

14:00 – 14:20 h
14:20 – 14:35 h
14:45 – 14:50 h
14:50 – 16:55 h
16:55 – 17:00 h
17:00 – 17:20 h
17:20 – 17:50 h
18:00 – 18:15 h
18:15 h

Sen. Cow Horse Open / Open Bridle Dry & Fence (3)

class in class NRCHA/AQHA/rasseoffen/EWU-Qualif / Sen. Open;

NRCHA Non Pro Ltd. 5k Dry & Fence (2)

Siegerehrung Cow Horse u. 5k (Reining Arena)

Abziehen

Ranch Cow Work Open (11) & Amateur (14) (5 min. / mit Pick Up Men/Woman / 2 x Abziehen)

Abziehen

Ranch Conformation Open (11)

Ranch Conformation Amateur (14)

Gemeinsame Siegerehrungen Open (11)
& Amateur (14) (Reining Arena)

Turnierende

Aufgrund der vielen Nennungen und dem knappen Zeitplan bitten wir ALLE Reiter darum bei den Prüfungen zügig ein- und wieder auszureiten! Vielen DANK und VIEL SPASS!

Sponsoren des Turniers



feedmyanimal



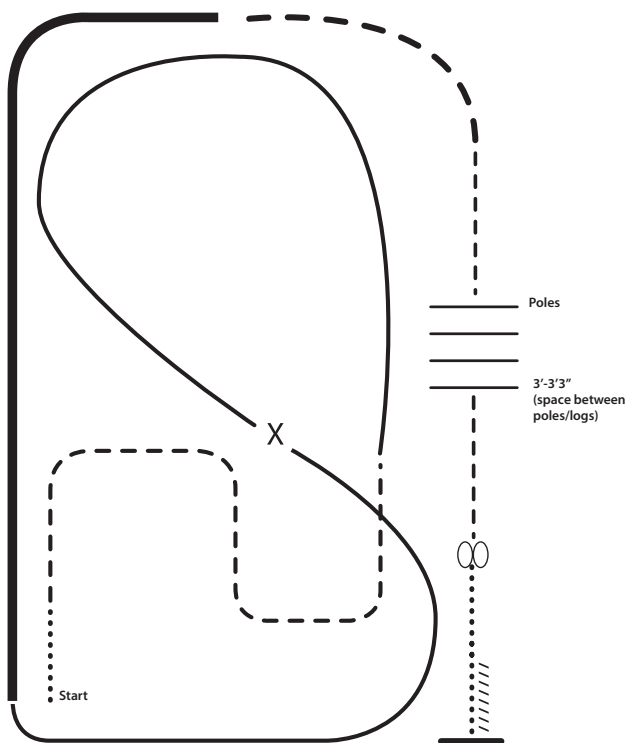

- X Lead Change
- • Walk
- - - Trot
- - - Ext trot
- — — Lope
- Ext Lope
- //// //// Back

- 1.** Walk
- 2.** Trot serpentine
- 3.** Lope left lead around the end of the arena and then diagonally across the arena
- 4.** Change leads (simple or flying) and
- 5.** Lope on the right lead around end of the arena
- 6.** Extend lope on the straight away and around corner to the center of the arena
- 7.** Extend trot around corner of the arena
- 8.** Collect to a trot
- 9.** Trot over poles
- 10.** Stop, do 360 degree turn each direction (either direction 1st) (L-R or R-L)
- 11.** Walk, stop and back

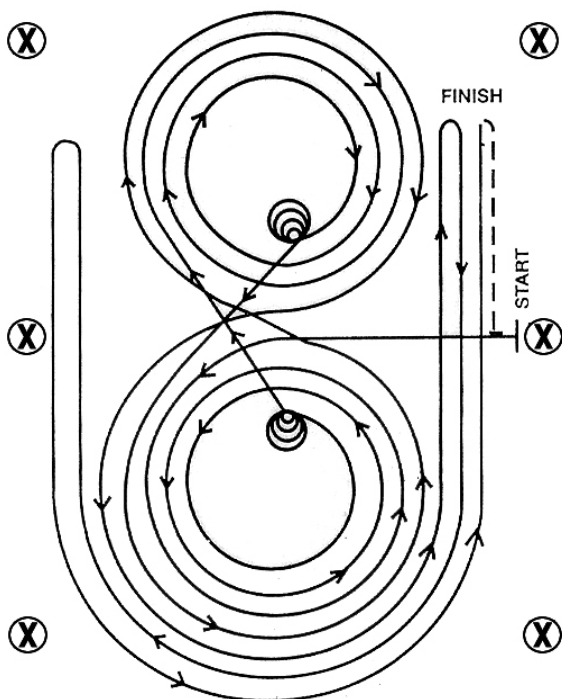

Horse must walk or stop prior to starting pattern.

Beginning at the center of the arena facing the left wall or fence.

1. Beginning on the left lead, complete three circles to the left: the first two circles large and fast; the third circle small and slow. Stop at the center of the arena.
2. Complete four spins to the left. Hesitate.
3. Beginning on the right lead, complete three circles to the right: the first two circles large and fast; the third circle small and slow. Stop at the center of the arena.
4. Complete four spins to the right. Hesitate.
5. Beginning on the left lead, run a large fast circle to the left, change leads at the center of the arena, run a large fast circle to the right, and change leads at the center of the arena. (Figure 8)
6. Continue around previous circle to the left but do not close this circle. Run up the right side of the arena past the center marker and do a right rollback at least 20 feet (6 meters) from the wall or fence - no hesitation.
7. Continue around previous circle but do not close this circle. Run up the left side of the arena past the center marker and do a left rollback at least 20 feet (6 meters) from the wall or fence - no hesitation.
8. Continue back around previous circle but do not close this circle. Run up the right side of the arena past the center marker and do a sliding stop at least 20 feet (6 meters) from the wall or fence. Back up at least 10 feet (3 meters). Hesitate to demonstrate completion of the pattern.

Rider may drop bridle to the designated judge.

Sponsoren des Turniers



Turnierfotograf:

Dirk Büttner, Luxcompany, Eppingen

mail@luxcompany.de



PATTERN 11-LOPE AWAY

Alle WCH Samstag

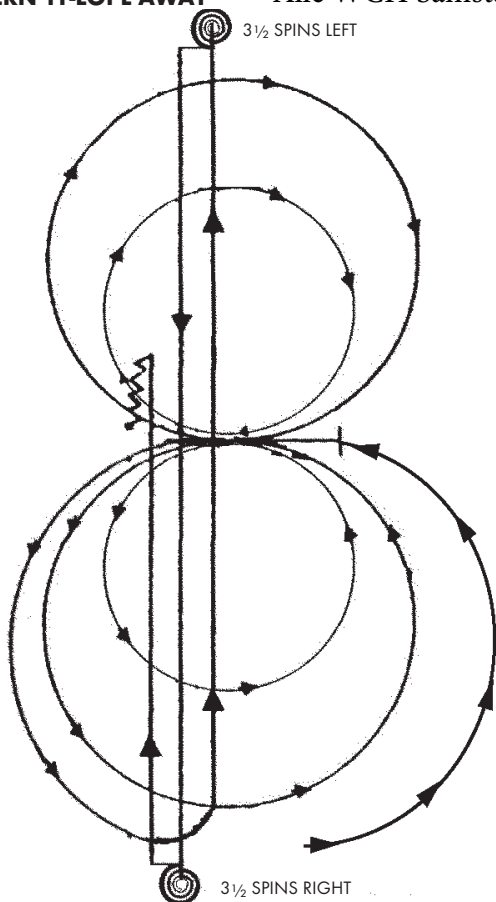

Begin on left lead. At the center, without stopping or breaking gait, begin pattern facing away from the judge. Refer to rule 20.6.

1. Beginning on the left lead complete 2 circles to the left, the first circle large and fast, and the second circle small and slow. Change leads at the center of the arena.
2. Complete 2 circles to the right, the first large and fast, the second small and slow. Change leads at the center of the arena.
3. Continue around end of arena without breaking gait or changing leads, run down center of the arena past the end marked, execute a square sliding stop.
4. Complete $3\frac{1}{2}$ spins to the left.
5. Run down center of arena past end marker, execute a square sliding stop.
6. Complete $3\frac{1}{2}$ spins to the right.
7. Run down center of arena past center marker, execute a square sliding stop. Back at least 10 feet. Hesitate to complete pattern.

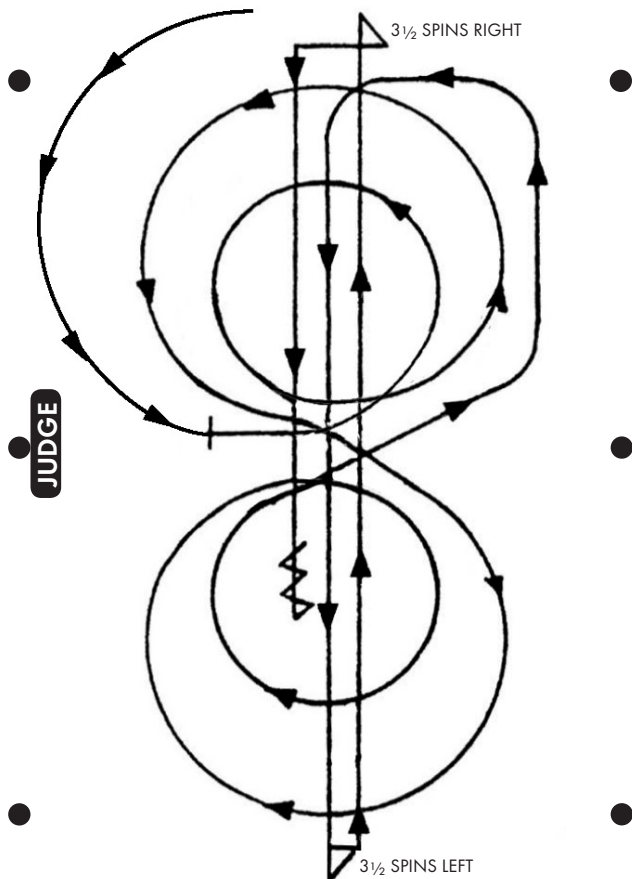

Start on left lead. At the center, without stopping or breaking gait, begin pattern facing away from the judge. Refer to rule 20.6.

1. Beginning on the left lead, complete 2 circles to the left. The first circle small and slow, the second circle large and fast. Change leads at the center of arena.
2. Complete 2 circles to the right. The first circle large and fast, the second circle small and slow. Change leads at the center of arena.
3. Continue around end of arena without breaking gait or changing leads, run down center of arena past end marker, and execute a square sliding stop.
4. Complete 3½ spins to the left.
5. Run down center of arena past end marker, and execute a square sliding stop.
6. Complete 3½ spins to the right.
7. Run down center of arena past center marker, and execute a square sliding stop.
8. Back up at least 10 feet. Hesitate to complete pattern.

Sponsoren des Turniers



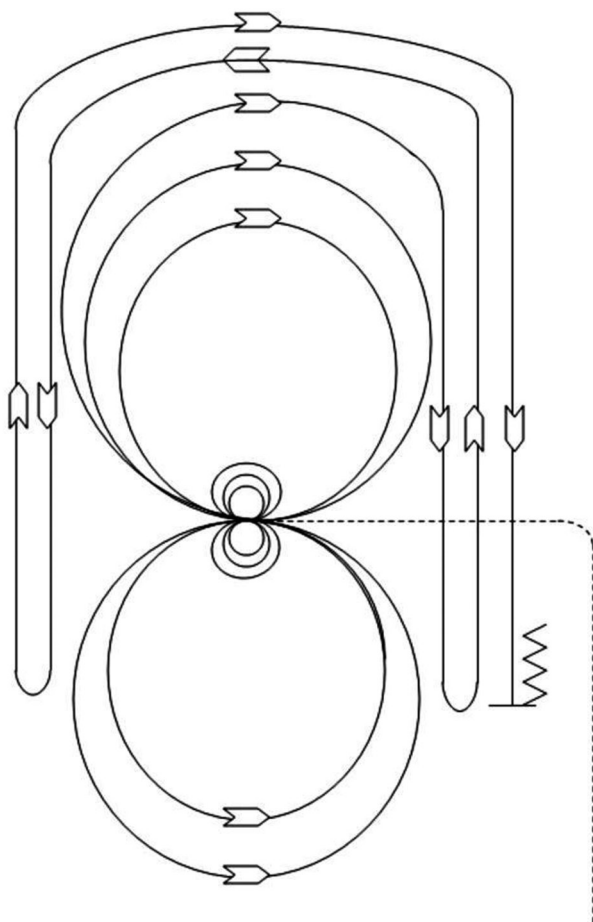

Mandatory Markers:

The judge shall indicate with markers on arena fence the center of the pattern.

Ride pattern as follows:

- 1.** Trot to center of arena and stop.
- 2.** Complete three spins in each direction
- 3.** Begin on right lead and lope two large fast circles to the right, change leads.
- 4.** Lope two large fast circles to the left, change leads.
- 5.** Begin a large circle to the right but do not close this circle. Run down the right side of the arena past the center marker and do a left roll back at least 20 feet from the wall or fence, no hesitation.
- 6.** Continue back around the previous circle but do not close this circle. Run down the left side of the arena past the center marker and do a right roll back at least 20 feet from the wall or fence, no hesitation.
- 7.** Continue back around previous circle but do not close this circle. Run down the right side of the arena past the center marker and do a sliding stop at least 20 feet from the wall or fence. Back up at least 10 feet. Hesitate to show completion of pattern.

Sponsoren des Turniers



OPEN & AMATEUR Ranch Trail & Ranch Riding Pattern Sinsheim Open 2017

1. Start
Ranch Trail

1. ride through gate to get in and close, walk over poles between cattles, walk through gate to get out and close

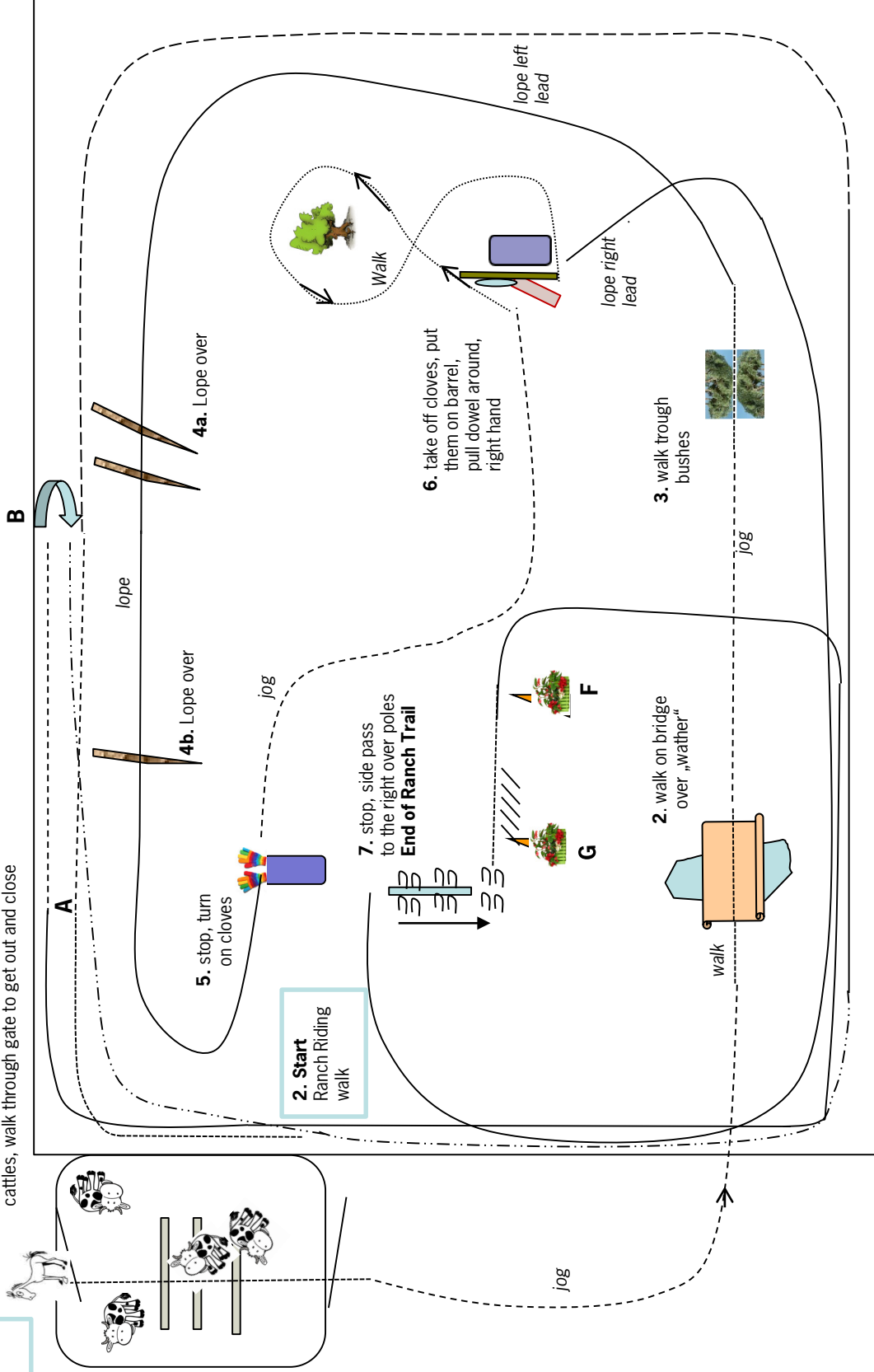

A **B** **C** **D** **E** **F** **G**

walk



jog



lope



extended jog



extended lope



back up



180° Turn



Ranch Riding Pattern # 1

1. Walk from start cone to A
2. Jog from A to B
3. Extended jog from B to C
4. Lope right lead from C to D
5. Extended lope from D to B
6. Stop at B, turn right, jog to A
7. Lope left lead from A to E
8. Turn toward the middle of the arena and continue to lope to F
9. Walk from F to G
10. Stop and back up approx. one horse length

walk



jog



lope



extended jog



extended lope



back up



180° Turn



Ranch Riding Pattern # 1

1. Walk from start cone to A
2. Jog from A to B
3. Extended jog from B to C
4. Lope right lead from C to D
5. Extended lope from D to B
6. Stop at B, turn right, jog to A
7. Lope left lead from A to E
8. Turn toward the middle of the arena and continue to lope to F
9. Walk from F to G
10. Stop and back up approx. one horse length

PATRICK SATTLER WORKING HORSES

Unser Trainingskonzept:

- Versatility Pferdeausbildung mit jahrelanger Erfahrung und Sachverstand
- 15 Zebu-Rinder für das Training in der Herde im Round Pen
- Fence Training: grosser eingezäunter Aussenplatz mit 80 x 30 m
- Arbeitsranch-Training mit Trail Hindernissen

Die jahrelangen Erfolge bestätigen unser Trainingskonzept:

- Ranch Horse Cup Südwest Sieger 2016 in allen 3 Divisions 2016 (Alle wurden Gesamtsieger in Open, Amateur & Einsteiger!)
- Außerdem Erfolge sowie nationale u. internationale Titel in der Versatility Ranch Horse: Internationaler Deutscher Meister 2015 DQHA
- Weitere Erfolge in der Versatility: AQHA Weltrangliste 2. Platz Junior Open in 2011, 4. Platz Junior und 6. Platz Senior Open 2016, ebenso aus dem Amateur Lager der 2. Platz i.d. AQHA Weltrangliste 2016!
- Mehrfacher Ranch Horse Cup Südwest Sieger Open in den vergangenen Jahren



Weitere Infos unter Tel. +49/173/9740025 | www.patricksattler.de | e-mail: info@patricksattler.de