



*Pattern Book*

STEPPING INTO THE HOOFPRIENTS OF THEIR ANCESTORS  
WHOM INCLUDE SOME OF THE BEST CUTTING,  
REINED COW AND REINING HORSES  
APHA AND AQHA HAVE  
EVER SEEN.



**C R H**  
*Colored Ranch Horses*

PROUD HOME OF  
EUROPEAN CHAMPION 2013 - GERMAN CHAMPION 2013  
AMATEUR WORKING COW HORSE

[WWW.COLORED-RANCH-HORSES.COM](http://WWW.COLORED-RANCH-HORSES.COM)

# WESTERN HORSEMANSHIP

## NOVICE YOUTH - Show 1 - 3

---

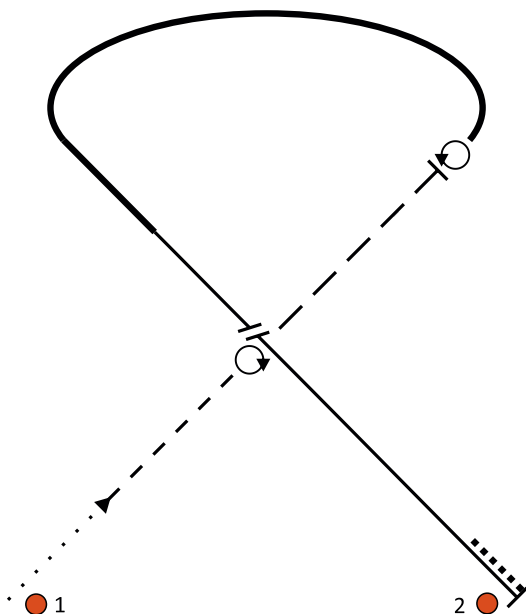

1. STARTING AT MARKER 1, WALK 15 FEET (CA. 4.5 METERS).
2. JOG TO THE MIDDLE OF THE ARENA.
3. 360° TURN TO THE RIGHT.
4. EXTENDED JOG.
5. STOP. 360° TURN TO THE LEFT.
6. LOPE WITH INCREASED SPEED AROUND END OF ARENA.
7. COLLECT TO THE LOPE BEFORE APPROACHING THE MIDDLE OF THE ARENA.
8. CHANGE LEADS (SIMPLE OR FLYING) AT THE MIDDLE OF THE ARENA.
9. LOPE ON THE RIGHT LEAD TO MARKER 2.
10. STOP AND BACK 2 HORSE LENGTHS. EXIT AT THE WALK OR JOG.

Note: The drawn description of this pattern is only intended for the general depiction of the pattern. Contestants should utilize the arena space to best exhibit their horses.

Diese grafische Beschreibung des Patterns ist nur zur generellen Veranschaulichung des Patterns vorgesehen. Die Teilnehmer sollten den Platz in der Arena so ausnutzen, dass sie ihr Pferd bestmöglich vorstellen können.

# WESTERN HORSEMANSHIP

## NOVICE AMATEUR - Show 1 - 3

---

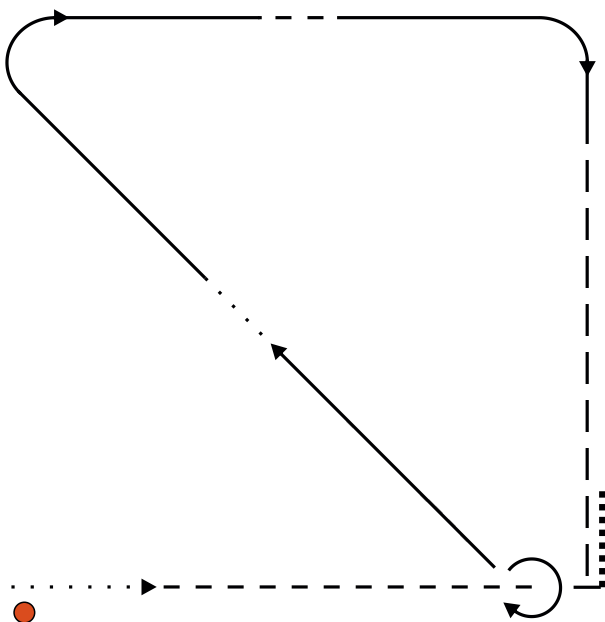

1. WALK 10 FEET (CA. 3 METERS), JOG ACROSS ARENA.
2. RIGHT TURN AND LOPE ON RIGHT LEAD.
3. SIMPLE CHANGE OF LEADS THROUGH A WALK.
4. COUNTER-LOPE THE CORNER, SIMPLE CHANGE OF LEADS THROUGH A JOG.
5. LOPE THE CORNER, EXTENDED JOG. HALT AND BACK
6. EXIT.

Note: The drawn description of this pattern is only intended for the general depiction of the pattern. Contestants should utilize the arena space to best exhibit their horses.

Diese grafische Beschreibung des Patterns ist nur zur generellen Veranschaulichung des Patterns vorgesehen. Die Teilnehmer sollten den Platz in der Arena so ausnutzen, dass sie ihr Pferd bestmöglich vorstellen können.

**WESTERN HORSEMANSHIP**  
**YOUTH 13 & UNDER - Show 1 - 3**  
**YOUTH 14 - 18 - Show 1 - 3**  
**AMATEUR - Show 4 - 6**

---

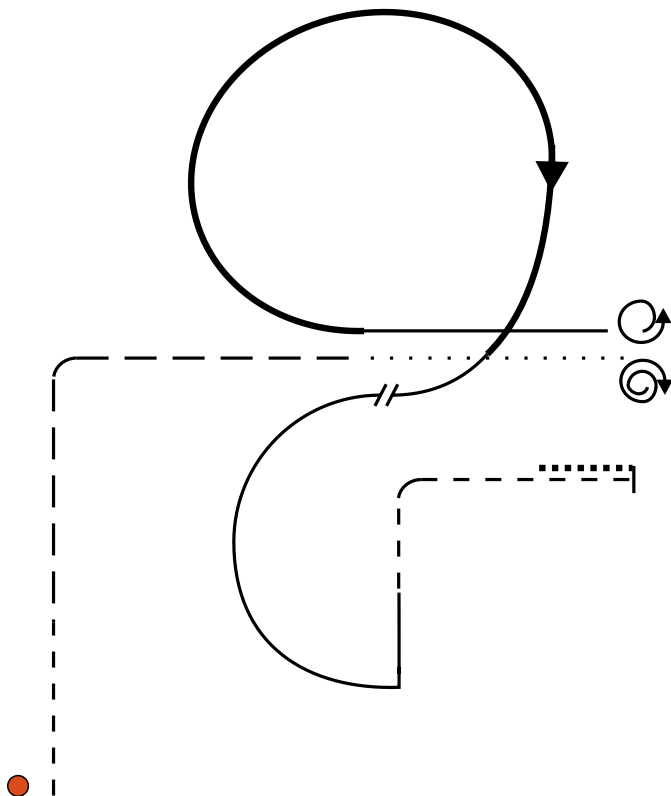

1. JOG 1/2 OF LINE, EXTENDED TROT TO THE MIDDLE. TRANSITION TO THE WALK WITHOUT LOSING FORWARD MOTION.
2. 1 1/4 TURNS LEFT, SLIGHT PAUSE, 1 3/4 TURNS TO RIGHT. LOPE ON RIGHT LEAD TO CENTER OF ARENA.
3. LOPE A LARGE CIRCLE TO THE RIGHT WITH SPEED.
4. COLLECT, CHANGE LEADS (SIMPLE OR FLYING)
5. LOPE 1/2 CIRCLE, SQUARE CORNER, JOG. STOP AND BACK
6. EXIT AT A WALK OR JOG.

Note: The drawn description of this pattern is only intended for the general depiction of the pattern. Contestants should utilize the arena space to best exhibit their horses.

Diese grafische Beschreibung des Patterns ist nur zur generellen Veranschaulichung des Patterns vorgesehen. Die Teilnehmer sollten den Platz in der Arena so ausnutzen, dass sie ihr Pferd bestmöglich vorstellen können.

# WESTERN HORSEMANSHIP

AMATEUR - Show 1 - 3

YOUTH 13 & UNDER - Show 4 - 6

YOUTH 14 - 18 - Show 4 - 6

---

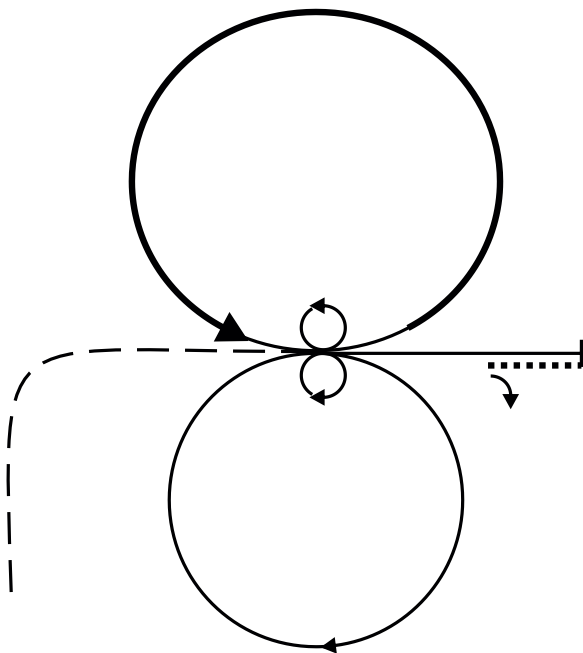

1. EXTENDED TROT TO CENTER, STOP.
2. 360° TURN TO THE RIGHT AND 360° TURN TO THE LEFT
3. LOPE A LARGE CIRCLE WITH SPEED - LEFT LEAD
4. CHANGE LEADS, LOPE A SMALL CIRCLE - RIGHT LEAD
5. AFTER COMPLETING CIRCLE, JOG, STOP AND BACK. 1/4 TURN TO THE RIGHT. PAUSE FOR BRIEF INSPECTION.
6. EXIT AT A WALK OR JOG

Note: The drawn description of this pattern is only intended for the general depiction of the pattern. Contestants should utilize the arena space to best exhibit their horses.

Diese grafische Beschreibung des Patterns ist nur zur generellen Veranschaulichung des Patterns vorgesehen. Die Teilnehmer sollten den Platz in der Arena so ausnutzen, dass sie ihr Pferd bestmöglich vorstellen können.

# WESTERN HORSEMANSHIP

## AMATEUR SELECT - Show 1 - 3

---

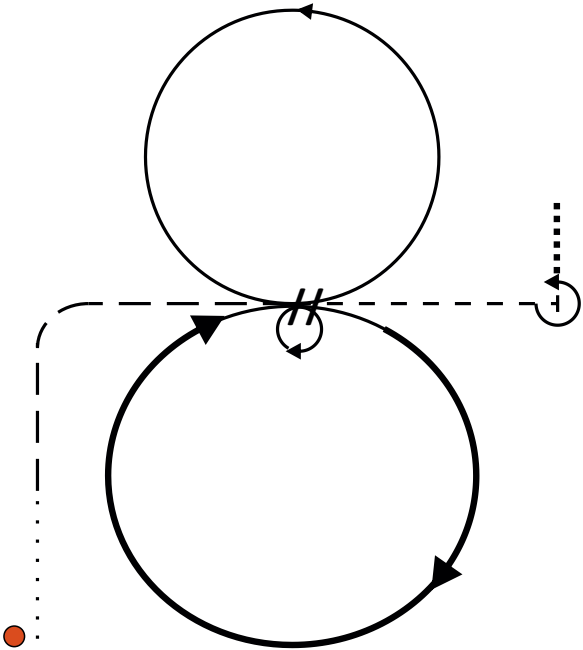

1. WALK 1/2 OF LINE. EXTENDED TROT UP AND TO MIDDLE.
2. STOP, 360° TO THE RIGHT.
3. LOPE A LARGE CIRCLE WITH SPEED TO THE RIGHT. COLLECT TO THE LOPE.
4. CHANGE LEADS (SIMPLE OR FLYING), LOPE A SMALLER CIRCLE TO THE LEFT.
5. JOG, STOP. 3/4 TURN LEFT. PAUSE FOR BRIEF INSPECTION, BACK.
6. EXIT.

Note: The drawn description of this pattern is only intended for the general depiction of the pattern. Contestants should utilize the arena space to best exhibit their horses.

Diese grafische Beschreibung des Patterns ist nur zur generellen Veranschaulichung des Patterns vorgesehen. Die Teilnehmer sollten den Platz in der Arena so ausnutzen, dass sie ihr Pferd bestmöglich vorstellen können.

# WESTERN HORSEMANSHIP

## AMATEUR SELECT - Show 4 - 6

---

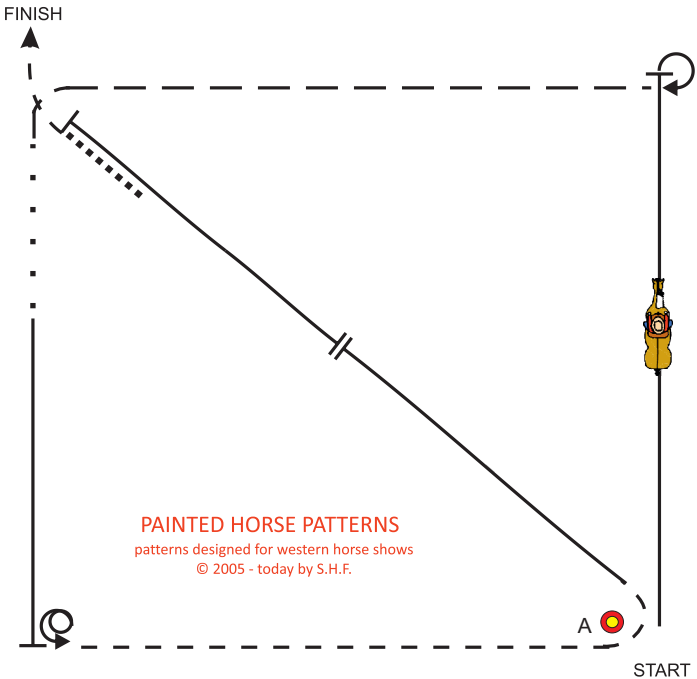

1. AT A LOPE LEFT LEAD IN STRAIGHT LINE
2. STOP. PERFORM A 270° TURN TO THE RIGHT ON THE HAUNCHES
3. EXTENDED JOG AROUND CORNER.
4. WALK 2 HORSE LENGTHS.
5. PICK UP A RIGHT LEAD LOPE TO CORNER.
6. STOP. PERFORM A 450° TURN TO THE LEFT ON THE HAUNCHES.
7. JOG TO AND AROUND A.
8. PICK UP LEFT LEAD AND LOPE ACROSS CENTER.
9. CHANGE LEADS (SIMPLE OR FLYING) AND CONTINUE TO CORNER.
10. STOP AND BACK A HORSE LENGTH.
11. JOG TO EXIT

Note: The drawn description of this pattern is only intended for the general depiction of the pattern. Contestants should utilize the arena space to best exhibit their horses.

Diese grafische Beschreibung des Patterns ist nur zur generellen Veranschaulichung des Patterns vorgesehen. Die Teilnehmer sollten den Platz in der Arena so ausnutzen, dass sie ihr Pferd bestmöglich vorstellen können.



# WESTERN HORSEMANSHIP

## YOUTH 13 & UNDER

## YOUTH 14 - 18

---

### FINALS

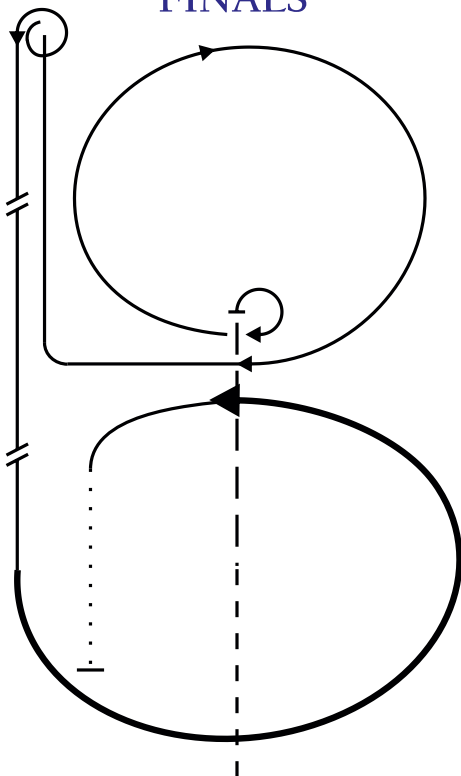

1. JOG 1/2 OF LINE, EXTENDED TROT TO CENTER.
2. 3/4 TURN TO RIGHT. LOPE A CADENCED CIRCLE TO THE RIGHT, CONTINUING ACROSS THE ARENA AND MAKING A CORNER TO THE RIGHT.
3. STOP, 1 1/2 TURNS LEFT, LOPE ON THE LEFT LEAD. EXECUTE A FLYING LEAD CHANGE.
4. CONTINUE DOWN THE LINE AND EXECUTE A SIMPLE CHANGE OF LEADS.
5. LOPE A PARTIAL CIRCLE WITH SPEED. COLLECT TO THE LOPE.
6. WALK, STOP AND BACK.
7. EXIT AT A WALK OR JOG.

Note: The drawn description of this pattern is only intended for the general depiction of the pattern. Contestants should utilize the arena space to best exhibit their horses.

Diese grafische Beschreibung des Patterns ist nur zur generellen Veranschaulichung des Patterns vorgesehen. Die Teilnehmer sollten den Platz in der Arena so ausnutzen, dass sie ihr Pferd bestmöglich vorstellen können.

# WESTERN HORSEMANSHIP AMATEUR

## FINALS

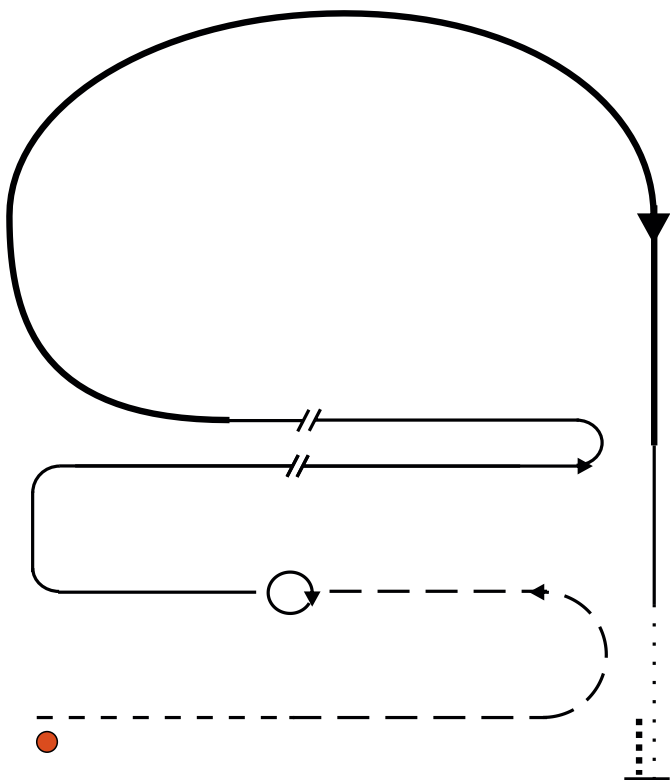

1. JOG, EXTENDED TROT, STOP
2. 360° TURN TO THE RIGHT, LOPE CORNERS, SIMPLE CHANGE OF LEADS THROUGH A JOG
3. LOPE TURN, FLYING CHANGE OF LEADS
4. LOPE WITH SPEED. COLLECT
5. TRANSITION TO A JOG WITHOUT LOSING FORWARD MOTION. STOP AND BACK
6. EXIT AT A WALK OR JOG.

Note: The drawn description of this pattern is only intended for the general depiction of the pattern. Contestants should utilize the arena space to best exhibit their horses.

Diese grafische Beschreibung des Patterns ist nur zur generellen Veranschaulichung des Patterns vorgesehen. Die Teilnehmer sollten den Platz in der Arena so ausnutzen, dass sie ihr Pferd bestmöglich vorstellen können.

# WESTERN HORSEMANSHIP

## AMATEUR SELECT

### FINALS

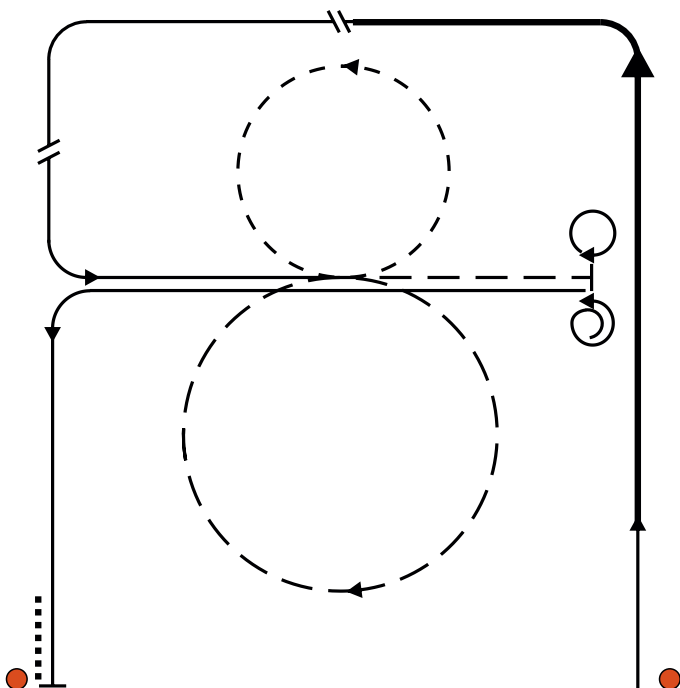

1. LOPE ON LEFT LEAD, BUILDING TO A LOPE WITH SPEED. CHANGE LEADS (SIMPLE OR FLYING)
2. COUNTER-LOPE CORNER, CHANGE LEADS (SIMPLE OR FLYING) AND LOPE CORNER TO MIDDLE OF ARENA.
3. TRANSITION TO A JOG AND JOG A CADENCED CIRCLE TO THE LEFT. EXTENDED TROT TO A LARGER CIRCLE TO THE RIGHT, CONTINUING ACROSS ARENA. STOP.
4. EXECUTE A 360° TURN TO THE RIGHT and 1 1/2 TURNS TO THE LEFT.
5. LOPE ON LEFT LEAD ACROSS ARENA, AROUND CORNER AND DOWN LINE. STOP AND BACK
6. EXIT AT A WALK OR JOG

Note: The drawn description of this pattern is only intended for the general depiction of the pattern. Contestants should utilize the arena space to best exhibit their horses.

Diese grafische Beschreibung des Patterns ist nur zur generellen Veranschaulichung des Patterns vorgesehen. Die Teilnehmer sollten den Platz in der Arena so ausnutzen, dass sie ihr Pferd bestmöglich vorstellen können.

# HUNT SEAT EQUITATION

## NOVICE YOUTH

---

### Shows Nr 1 - 3

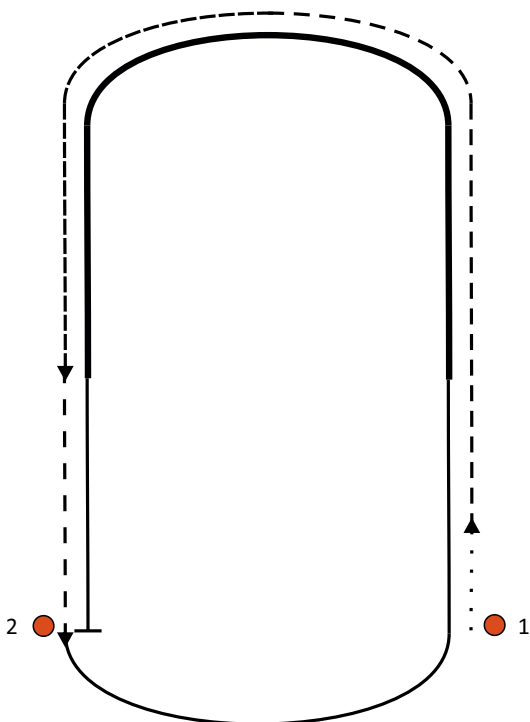

1. AT MARKER 1, WALK 10 FEED (CA. 3 METERS).
2. TROT ON THE RIGHT DIAGONAL.
3. MIDWAY OF THE END, TROT IN A 2 POINT POSITION
4. MIDWAY DOWN THE LONG LINE, EXECUTE A SITTING TROT.
5. AT MARKER 2, CANTER ON THE LEFT LEAD.
6. MIDWAY OF THE LONG LINE, CANTER IN A 2 POINT POSITION.  
CONTINUE AROUND THE END AND HALF WAY DOWN THE LONG LINE.
7. CANTER TO MARKER 2.
8. STOP AT MARKER 2.

Note: The drawn description of this pattern is only intended for the general depiction of the pattern. Contestants should utilize the arena space to best exhibit their horses.

Diese grafische Beschreibung des Patterns ist nur zur generellen Veranschaulichung des Patterns vorgesehen. Die Teilnehmer sollten den Platz in der Arena so ausnutzen, dass sie ihr Pferd bestmöglich vorstellen können.

# HUNT SEAT EQUITATION NOVICE AMATEUR

---

## Shows Nr 1 - 3

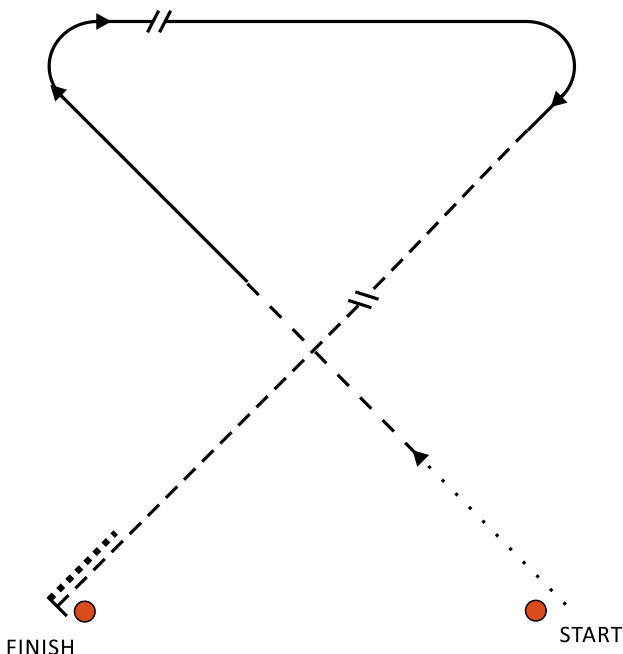

1. WALK, SITTING TROT.
2. RIGHT LEAD, CHANGE LEADS (SIMPLE OR FLYING)
3. LEFT LEAD AROUND CORNER.
4. POSTING TROT, RIGHT DIAGONAL, CHANGE TO LEFT DIAGONAL
5. HALT. BACK APPROX. 2 HORSE LENGTHS. PAUSE.
6. EXIT

Note: The drawn description of this pattern is only intended for the general depiction of the pattern. Contestants should utilize the arena space to best exhibit their horses.

Diese grafische Beschreibung des Patterns ist nur zur generellen Veranschaulichung des Patterns vorgesehen. Die Teilnehmer sollten den Platz in der Arena so ausnutzen, dass sie ihr Pferd bestmöglich vorstellen können.

HUNT SEAT EQUITATION  
YOUTH 13 & UNDER - Show 1 - 3  
YOUTH 14 - 18 - Show 1 - 3  
AMATEUR - Show 4 - 6

---

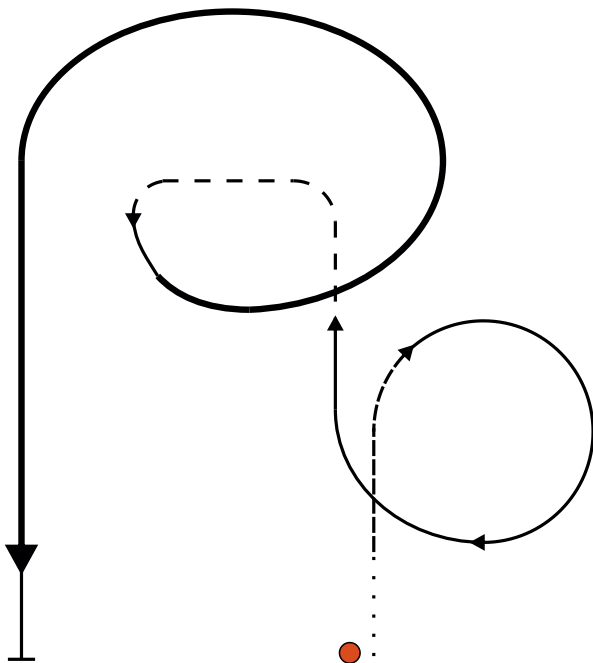

1. WALK
2. TWO POINT POSITION TROT.
3. CANTER RIGHT LEAD.
4. POSTING TROT.
5. HAND GALLOP, COLLECT.
6. HALT, LOOSEN REIN.
7. EXIT AT A WALK.

Note: The drawn description of this pattern is only intended for the general depiction of the pattern. Contestants should utilize the arena space to best exhibit their horses.

Diese grafische Beschreibung des Patterns ist nur zur generellen Veranschaulichung des Patterns vorgesehen. Die Teilnehmer sollten den Platz in der Arena so ausnutzen, dass sie ihr Pferd bestmöglich vorstellen können.

# HUNT SEAT EQUITATION

AMATEUR - Show 1 - 3

YOUTH 13 & UNDER - Show 4 - 6

YOUTH 14 - 18 - Show 4 - 6

---

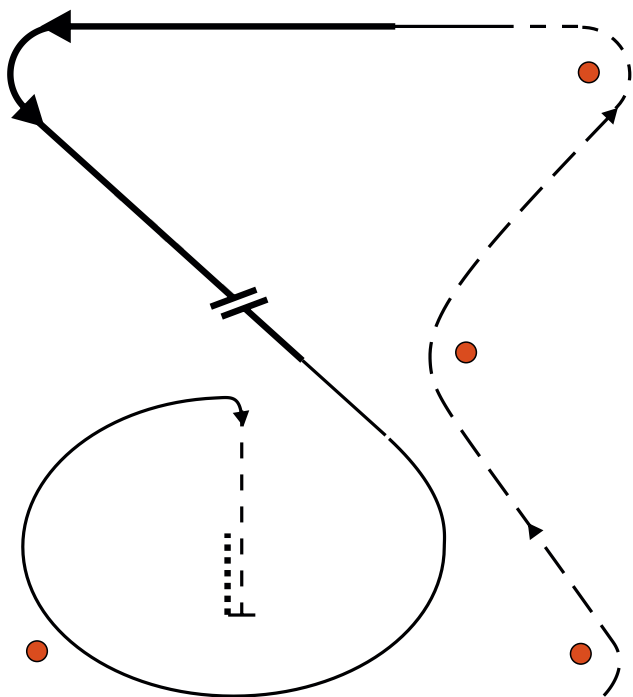

1. POSTING TROT, DEMONSTRATING CORRECT BEND OF HORSE THROUGH THE LOOP
2. CANTER LEFT LEAD, MOVING GRADUALLY INTO A HAND GALLOP
3. CHANGE LEADS, FLYING OR SIMPLE
4. COLLECT CANTER IN THE RIGHT CIRCLE
5. SITTING TROT. HALT, BACK UP APPROX. 2 HORSE LENGTHS.
6. EXIT

Note: The drawn description of this pattern is only intended for the general depiction of the pattern. Contestants should utilize the arena space to best exhibit their horses.

Diese grafische Beschreibung des Patterns ist nur zur generellen Veranschaulichung des Patterns vorgesehen. Die Teilnehmer sollten den Platz in der Arena so ausnutzen, dass sie ihr Pferd bestmöglich vorstellen können.

# HUNT SEAT EQUITATION

## AMATEUR SELECT - Show 1 - 3

---

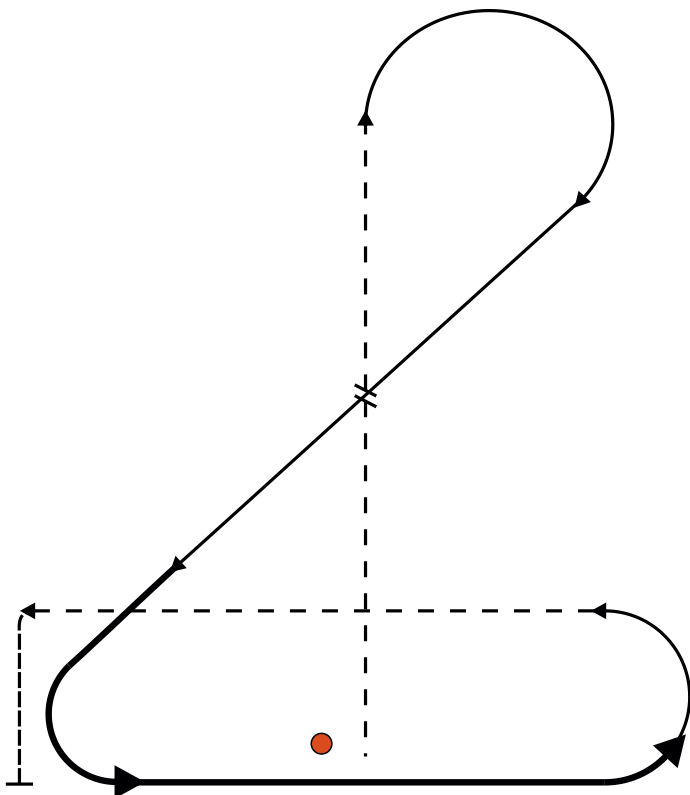

1. POSTING TROT, RIGHT DIAGONAL. AT „X“ CHANGE DIAGONALS.
2. COLLECTED CANTER, RIGHT LEAD. CHANGE LEADS (SIMPLE OR FLYING)
3. GRADUALLY INCREASE TO A HAND GALLOP BEFORE COLLECTING BACK TO A CANTER.
4. POSTING TROT, RIGHT DIAGONAL.
5. SITTING TROT, HALT.

Note: The drawn description of this pattern is only intended for the general depiction of the pattern. Contestants should utilize the arena space to best exhibit their horses.

Diese grafische Beschreibung des Patterns ist nur zur generellen Veranschaulichung des Patterns vorgesehen. Die Teilnehmer sollten den Platz in der Arena so ausnutzen, dass sie ihr Pferd bestmöglich vorstellen können.



# HUNT SEAT EQUITATION

## AMATEUR SELECT - Show 4 - 6

---

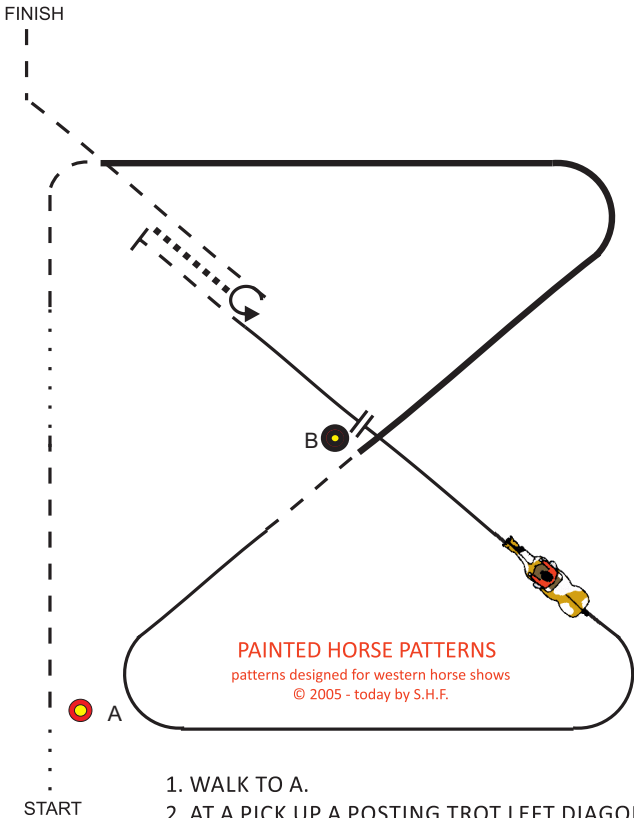

1. WALK TO A.
2. AT A PICK UP A POSTING TROT LEFT DIAGONAL.
3. WHEN EVEN WITH B WALK 2 HORSE LENGTHS.
4. PICK UP A POSTING TROT RIGHT DIAGONAL.
5. AT CORNER HAND GALLOP (RIGHT LEAD) AROUND TO B.
6. AT B PICK UP A POSTING TROT RIGHT DIAGONAL 2 HORSE LENGTHS.
7. PICK UP LEFT LEAD CANTER AROUND TO B.
8. AT B CHANGE LEADS (SIMPLE OR FLYING)
9. BREAK TO A SITTING TROT, 2 HORSE LENGTHS.
10. STOP AND BACK A HORSE LENGTH
11. EXECUTE A 360° TURN TO THE LEFT ON THE FOREHAND.
12. SITTING TROT TO EXIT.

Note: The drawn description of this pattern is only intended for the general depiction of the pattern. Contestants should utilize the arena space to best exhibit their horses.

Diese grafische Beschreibung des Patterns ist nur zur generellen Veranschaulichung des Patterns vorgesehen. Die Teilnehmer sollten den Platz in der Arena so ausnutzen, dass sie ihr Pferd bestmöglich vorstellen können.

# HUNT SEAT EQUITATION AMATEUR

---

## FINALS

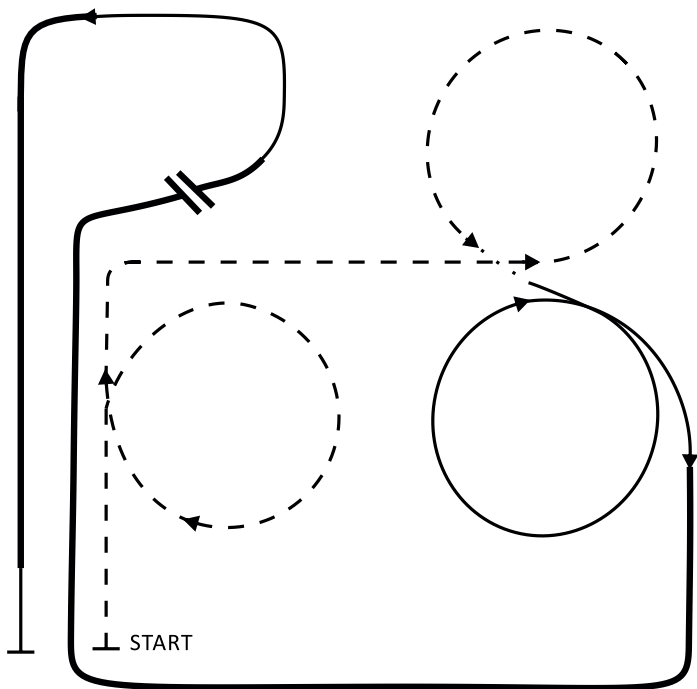

START WITHOUT IRONS (MAYBE CROSSED OVER NECK)

1. POSTING TROT RIGHT CIRCLE, RIDING ACROSS ARENA INTO A LEFT CIRCLE
2. WALK, PICK UP IRONS, RIGHT CANTER CIRCLE, MOVING INTO A HAND GALLOP AS YOU RIDE AROUND ARENA.
3. CHANGE LEADS, COLLECT TO CANTER.
4. MOVE INTO THE HAND GALLOP DOWN THE LONG SIDE.
5. HALT, LOOSEN REINS, ADDRESS REINS.

Note: The drawn description of this pattern is only intended for the general depiction of the pattern. Contestants should utilize the arena space to best exhibit their horses.

Diese grafische Beschreibung des Patterns ist nur zur generellen Veranschaulichung des Patterns vorgesehen. Die Teilnehmer sollten den Platz in der Arena so ausnutzen, dass sie ihr Pferd bestmöglich vorstellen können.

# HUNT SEAT EQUITATION AMATEUR SELECT

---

## FINALS

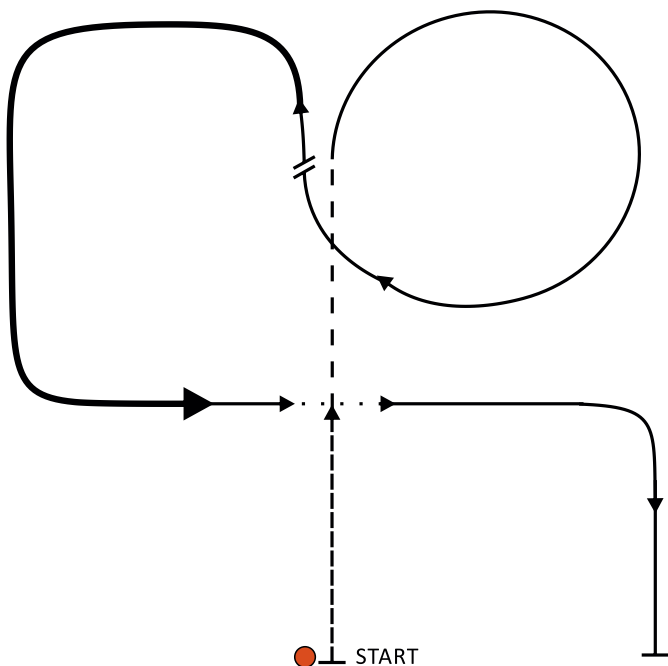

START WITHOUT IRONS (MAYBE CROSSED OVER NECK)

1. SITTING TROT 1/2 OF LINE.
2. POSTING TROT 1/2 OF LINE.
3. CANTER CIRCLE, RIGHT LEAD. CHANGE LEADS (SIMPLE OR FLYING)
4. CANTER CIRCLE, LEFT LEAD, BUILDING TO HAND GALLOP BEFORE COLLECTING.
5. CHANGE LEADS THROUGH A WALK
6. CANTER RIGHT LEAD. HALT
7. EXIT

Note: The drawn description of this pattern is only intended for the general depiction of the pattern. Contestants should utilize the arena space to best exhibit their horses.

Diese grafische Beschreibung des Patterns ist nur zur generellen Veranschaulichung des Patterns vorgesehen. Die Teilnehmer sollten den Platz in der Arena so ausnutzen, dass sie ihr Pferd bestmöglich vorstellen können.

# HUNT SEAT EQUITATION

## YOUTH 13 & UNDER

## YOUTH 14 - 18

---

### FINALS

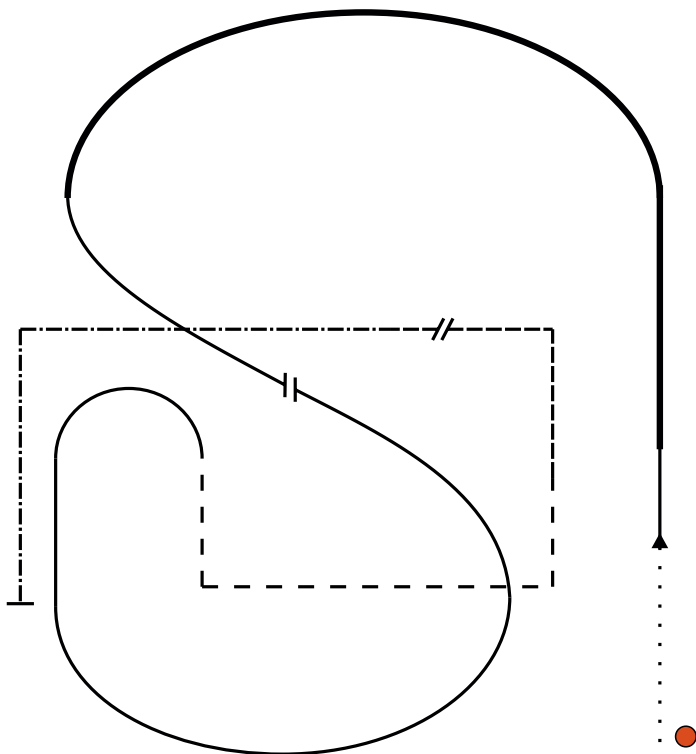

1. WALK.
2. CANTER LEFT LEAD, BUILDING INTO A HAND GALLOP.
3. COLLECT TO CANTER, CHANGE LEADS (SIMPLE OR FLYING).
4. SITTING TROT AROUND TWO CORNERS.
5. POSTING TROT AROUND ONE CORNER.
6. CHANGE DIAGONAL, TROT IN 2 POINT POSITION, HALT.
7. EXIT AT A WALK OR TROT.

Note: The drawn description of this pattern is only intended for the general depiction of the pattern. Contestants should utilize the arena space to best exhibit their horses.

Diese grafische Beschreibung des Patterns ist nur zur generellen Veranschaulichung des Patterns vorgesehen. Die Teilnehmer sollten den Platz in der Arena so ausnutzen, dass sie ihr Pferd bestmöglich vorstellen können.

# REINING - WESTERN RIDING WORKING COWHORSE

---

<u>REINING:</u>	Show 1 - 3	Show 4 - 6
Novice Youth	# 6	-
Youth 13 & Under	# 8	# 6
Youth 14-18	# 8	# 6
Novice Amateur	# 6	-
Amateur Select	# 2	# 9
Amateur	# 2	# 9
Open Junior Bit	# 6	# 2
Jr. Hackamore / Snaffle Bit	# 8	# 6
Open Senior	# 4	# 9

## WESTERN RIDING:

Novice Youth	Green # 1	-
Youth 13 & Under	# 1	# 4
Youth 14-18	# 1	# 5
Novice Amateur	Green # 1	-
Amateur	# 4	# 2
Open Junior	Green # 1	Green # 4
Open Senior	# 4	# 2
Green Horse	Green # 4	Green # 1

## WORKING COW HORSE:

Amateur	# 1	# 4
Open Junior	# 1	# 4
Open Senior	# 5	# 11

All patterns can be found in the  
2014 Official Handbook of Rules and Regulations  
issued by the AMERICAN QUARTER HORSE ASSOCIATION

Alle aufgelisteten Pattern sind Bestandteil des  
2014 Official Handbook of Rules and Regulations  
herausgegeben von der AMERICAN QUARTER HORSE ASSOCIATION

# REINING - WESTERN RIDING WORKING COWHORSE

---

## FINALS

### REINING:

Youth 13 & Under	# 4
Youth 14-18	# 4
Amateur Select	# 6
Amateur	# 11
Open Junior Bit	# 3
Open Junior Hackamore / Snaffle Bit	# 5
Open Senior	# 11

### WESTERN RIDING:

Youth 13 & Under	# 2
Youth 14-18	# 2
Amateur	# 3
Open Junior	Green # 2
Open Senior	# 3

### WORKING COW HORSE:

Amateur	# 5
Open Junior	# 5
Open Senior	# 12

All patterns can be found in the  
2014 Official Handbook of Rules and Regulations  
issued by the AMERICAN QUARTER HORSE ASSOCIATION

Alle aufgelisteten Pattern sind Bestandteil des  
2014 Official Handbook of Rules and Regulations  
herausgegeben von der AMERICAN QUARTER HORSE ASSOCIATION

# SHOWMANSHIP AT HALTER

## NOVICE YOUTH

---

### Shows Nr 1 - 3

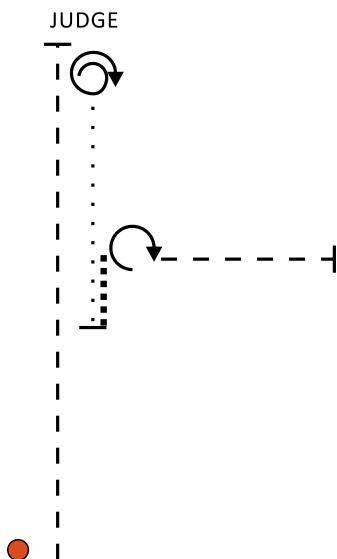

1. TROT TO JUDGE.
2. SET UP FOR FULL INSPECTION.
3. AFTER INSPECTION, EXECUTE 1 1/2 TURNS AND WALK 1/2 OF LINE
4. STOP, BACK 2 HORSE LENGTHS.
5. 3/4 TURN AND TROT.
6. HALT AND SET-UP. WHEN SET UP IS COMPLETE, EXIT AT A WALK OR JOG

Note: The drawn description of this pattern is only intended for the general depiction of the pattern. Contestants should utilize the arena space to best exhibit their horses.

Diese grafische Beschreibung des Patterns ist nur zur generellen Veranschaulichung des Patterns vorgesehen. Die Teilnehmer sollten den Platz in der Arena so ausnutzen, dass sie ihr Pferd bestmöglich vorstellen können.

# SHOWMANSHIP AT HALTER

## NOVICE AMATEUR

---

### Shows Nr 1 - 3

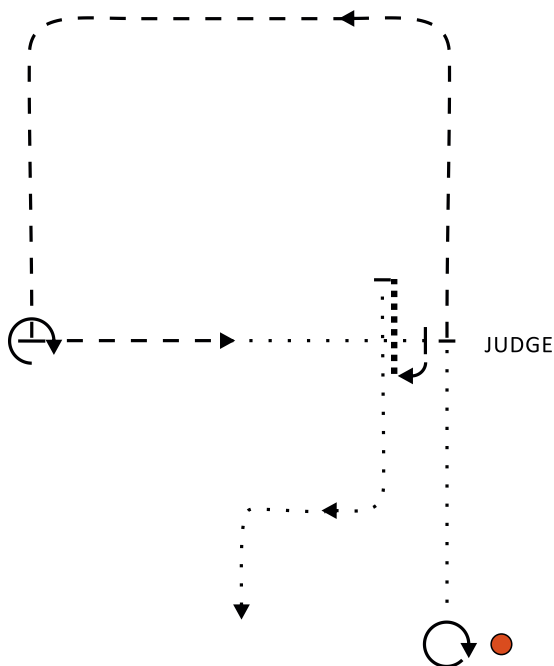

1. EXECUTE ONE 360° TURN AT MARKER
2. WALK FROM MARKER 1 TO A POSITION IN FRONT OF JUDGE.
3. SET UP. HESITATE AND TROT STRAIGHT AWAY.
4. TROT TWO CORNERS AND STOP.
5. EXECUTE 3/4 TURN TO THE RIGHT.
6. TROT HALFWAY TO THE JUDGE.
7. WALK HALF WAY TO THE JUDGE.
8. STOP AND SET UP FOR INSPECTION.
9. AFTER INSPECTION, TURN 1/4 TO THE RIGHT.
10. BACK TWO HORSE LENGTHS.
11. WALK OR JOG TO EXIT.

Note: The drawn description of this pattern is only intended for the general depiction of the pattern. Contestants should utilize the arena space to best exhibit their horses.

Diese grafische Beschreibung des Patterns ist nur zur generellen Veranschaulichung des Patterns vorgesehen. Die Teilnehmer sollten den Platz in der Arena so ausnutzen, dass sie ihr Pferd bestmöglich vorstellen können.



**SHOWMANSHIP AT HALTER**  
**YOUTH 13 & UNDER - Show 1 - 3**  
**YOUTH 14 - 18 - Show 1 - 3**  
**AMATEUR - Show 4 - 6**

---

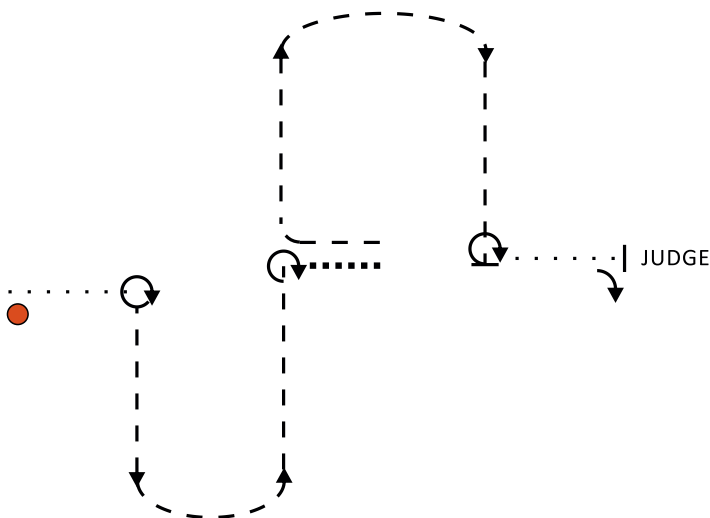

1. WALK 1 1/4 TURN.
2. TROT.
3. STOP. 3/4 TURN, BACK 2 HORSE LENGTHS.
4. TROT.
5. STOP, 3/4 TURN, WALK TO JUDGE.
6. SET UP FOR INSPECTION.
7. AFTER INSPECTION, 1/4 TURN, THEN EXIT AT A WALK OR TROT.

Note: The drawn description of this pattern is only intended for the general depiction of the pattern. Contestants should utilize the arena space to best exhibit their horses.

Diese grafische Beschreibung des Patterns ist nur zur generellen Veranschaulichung des Patterns vorgesehen. Die Teilnehmer sollten den Platz in der Arena so ausnutzen, dass sie ihr Pferd bestmöglich vorstellen können.

# SHOWMANSHIP AT HALTER

## AMATEUR - Show 1 - 3

### YOUTH 13 & UNDER - Show 4 - 6

### YOUTH 14 - 18 - Show 4 - 6

---

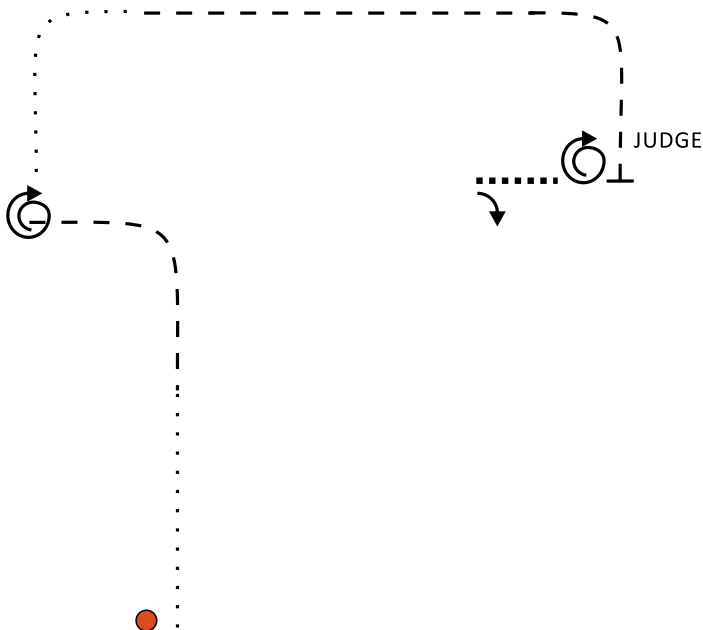

1. WALK HALF OF THE LINE, TROT HALF OF THE LINE AND CORNER
2. STOP. 1 1/4 TURN (450°)
3. WALK AROUND CORNER, TROT AROUND CORNER
4. STOP WITH HINDQUARTERS EVEN WITH JUDGE. SET UP FOR INSPECTION.
5. AFTER INSPECTION 1 3/4 TURN (630°), BACK TWO HORSE LENGTHS, 1/4 TURN.
6. EXIT ALONG WALL AT A WALK OR TROT.

Note: The drawn description of this pattern is only intended for the general depiction of the pattern. Contestants should utilize the arena space to best exhibit their horses.

Diese grafische Beschreibung des Patterns ist nur zur generellen Veranschaulichung des Patterns vorgesehen. Die Teilnehmer sollten den Platz in der Arena so ausnutzen, dass sie ihr Pferd bestmöglich vorstellen können.

# SHOWMANSHIP AT HALTER AMATEUR SELECT - Show 1 - 3

---

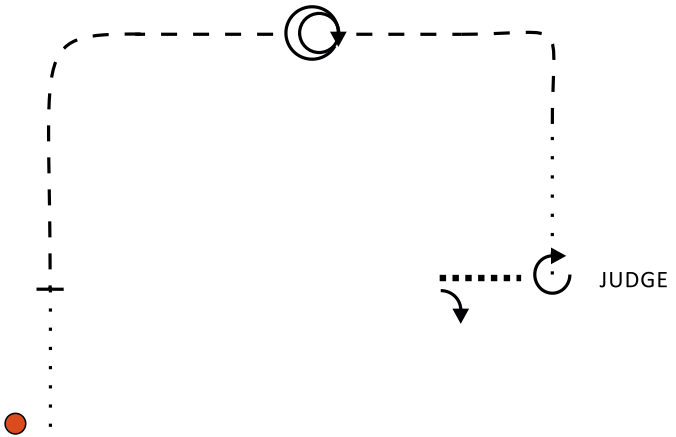

1. WALK. WHAN ACROSS FROM JUDGE, STOP AND SET UP HORSE FOR BRIEF INSPECTION.
2. TROT CORNER, HALT. EXECUTE TWO TURNS.
3. TROT CORNER, WALK, HALT. 270° TURN
4. SET UP FOR INSPECTION.
5. BACK, 1/4 TURN AND EXIT AT A WALK OR TROT.

Note: The drawn description of this pattern is only intended for the general depiction of the pattern. Contestants should utilize the arena space to best exhibit their horses.

Diese grafische Beschreibung des Patterns ist nur zur generellen Veranschaulichung des Patterns vorgesehen. Die Teilnehmer sollten den Platz in der Arena so ausnutzen, dass sie ihr Pferd bestmöglich vorstellen können.



Michaela Kayser  
TRAININGSSTALL

# SHOWMANSHIP AT HALTER

## AMATEUR SELECT - Show 4 - 6

---

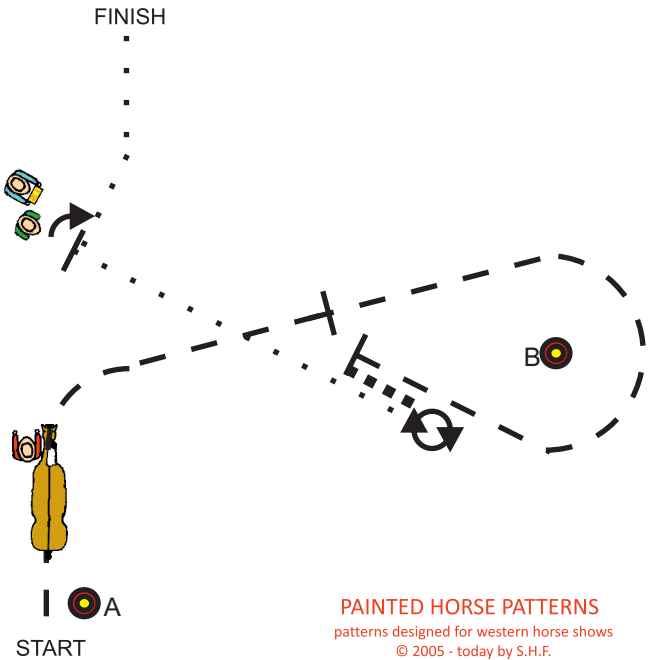

1. AT A TROT TOWARDS B.
2. STOP HALFWAY BETWEEN B AND JUDGE.
3. TROT AROUND B.
4. STOP HALFWAY BETWEEN B & JUDGE. BACK A HORSE LENGTH AND EXECUTE A 360° TURN.
5. WALK TO JUDGE AND SET UP FOR INSPECTION.
6. WHEN DISMISSED PERFORM 90° TURN TO THE RIGHT.
7. WALK TO EXIT.

Note: The drawn description of this pattern is only intended for the general depiction of the pattern. Contestants should utilize the arena space to best exhibit their horses.

Diese grafische Beschreibung des Patterns ist nur zur generellen Veranschaulichung des Patterns vorgesehen. Die Teilnehmer sollten den Platz in der Arena so ausnutzen, dass sie ihr Pferd bestmöglich vorstellen können.

# SHOWMANSHIP AT HALTER

## YOUTH 13 & UNDER

## YOUTH 14 - 18

---

### FINALS

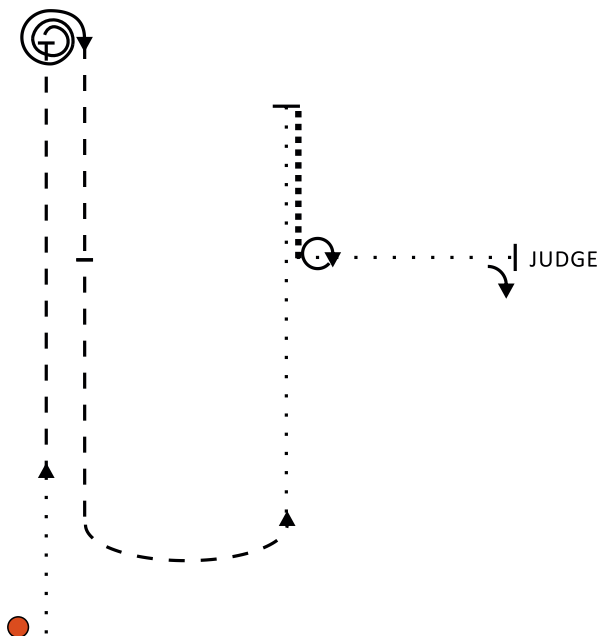

1. WALK 1/3 OF LONG LINE.
2. TROT 2/3 OF LONG LINE.
3. STOP. 2 1/2 TURNS.
4. TROT. STOP AND SET-UP FOR BRIEF INSPECTION.
5. TROT, WALK.
6. STOP, BACK, 1 1/4 TURN.
7. WALK TO JUDGE AND SET-UP FOR FULL INSPECTION.
8. WHEN DISMISSED, 1/4 TURN, THEN WALK OR TROT TO WALL.

Note: The drawn description of this pattern is only intended for the general depiction of the pattern. Contestants should utilize the arena space to best exhibit their horses.

Diese grafische Beschreibung des Patterns ist nur zur generellen Veranschaulichung des Patterns vorgesehen. Die Teilnehmer sollten den Platz in der Arena so ausnutzen, dass sie ihr Pferd bestmöglich vorstellen können.

# SHOWMANSHIP AT HALTER AMATEUR SELECT

## FINALS

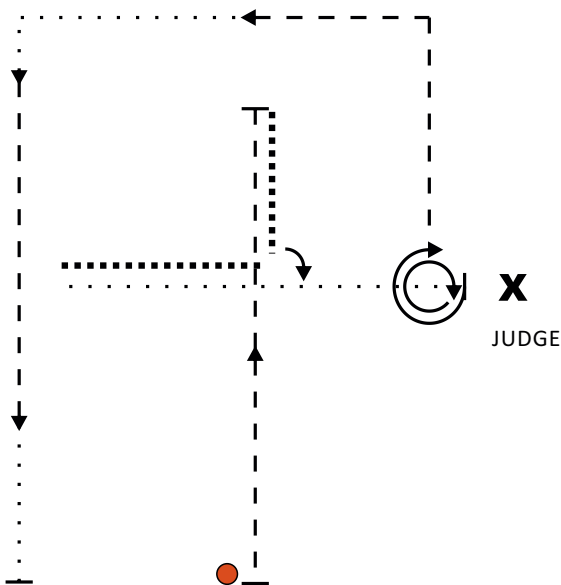

1. TROT PAST JUDGE. STOP
2. BACK, 1/4 TURN RIGHT, BACK.
3. WALK TO JUDGE, SET UP FOR FULL INSPECTION
4. TURN 3/4 TURN (270°), SET UP FOR BRIEF INSPECTION, THEN ONE FULL TURN (360°).
5. TROT AROUND CORNER, WALK, TROT 2/3 OF LINE. STOP TO END PATTERN.

Note: The drawn description of this pattern is only intended for the general depiction of the pattern. Contestants should utilize the arena space to best exhibit their horses.

Diese grafische Beschreibung des Patterns ist nur zur generellen Veranschaulichung des Patterns vorgesehen. Die Teilnehmer sollten den Platz in der Arena so ausnutzen, dass sie ihr Pferd bestmöglich vorstellen können.

# SHOWMANSHIP AT HALTER AMATEUR

## FINALS

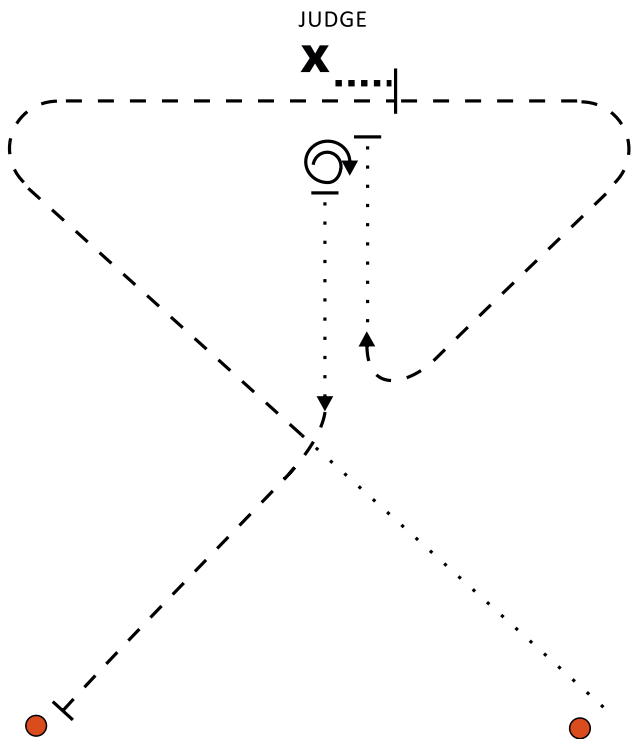

1. WALK ACROSS ARENA. TROT CORNER AND TROT PAST JUDGE. STOP AND BACK UP UNTIL EVEN WITH JUDGE
2. SET UP FOR BRIEF INSPECTION
3. TROT ACROSS ARENA AND AROUND CORNER. WALK TO JUDGE
4. SET UP FOR FULL INSPECTION.
5. AFTER INSPECTION, 1 1/2 TURNS AND WALK. TROT TO MARKER. STOP.
6. EXIT.

Note: The drawn description of this pattern is only intended for the general depiction of the pattern. Contestants should utilize the arena space to best exhibit their horses.

Diese grafische Beschreibung des Patterns ist nur zur generellen Veranschaulichung des Patterns vorgesehen. Die Teilnehmer sollten den Platz in der Arena so ausnutzen, dass sie ihr Pferd bestmöglich vorstellen können.

# RANCH PLEASURE

NOVICE YOUTH - YOUTH  
NOVICE AMATEUR - OPEN JUNIOR  
GREEN - Show 1 - 3

---

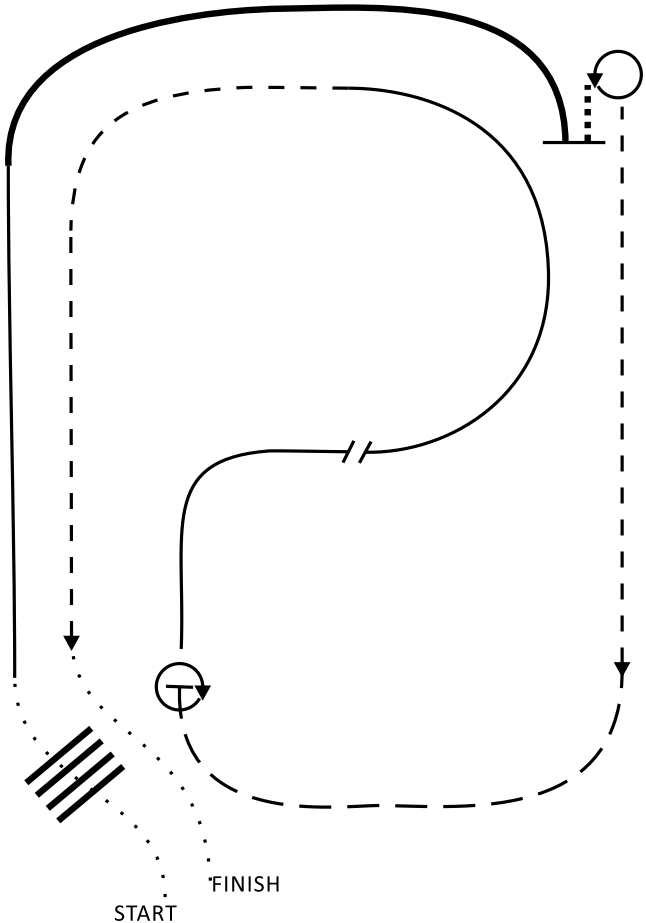

1. WALK IN ARENA AND OVER LOGS.
2. LOPE ON RIGHT LEAD.
3. EXTEND THE LOPE.
4. STOP, BACK AND TURN 360° LEFT
5. JOG
6. EXTENDED JOG
7. STOP - TURN 360° RIGHT
8. LOPE ON RIGHT LEAD, CHANGE LEADS (SIMPLE OR FLYING).
9. CONTINUE LOPING LEFT LEAD.
10. JOG
11. EXTENDED JOG.
12. WALK TO EXIT.





# RANCH PLEASURE

## YOUTH OPEN JUNIOR

### FINALS

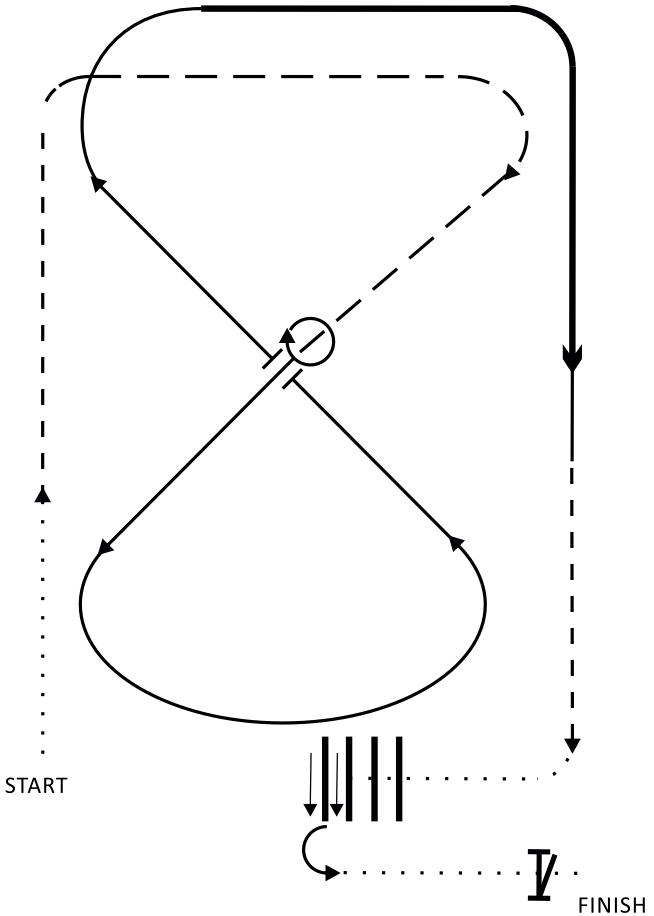

1. WALK.
2. JOG.
3. EXTENDED TROT.
4. STOP, 360° TURN TO THE LEFT.
5. LOPE LEFT LEAD.
6. CHANGE LEADS.
7. LOPE RIGHT LEAD.
8. EXTENDED LOPE, COLLECT TO A LOPE.
9. JOG.
10. WALK.
11. WALK OVER LOGS AND SIDEPASS LOG. 180° TURN TO THE LEFT.
12. WALK TO GATE, RIGHT HAND PUSH.

RANCH PLEASURE  
AMATEUR  
OPEN SENIOR  
AMATEUR SELECT

---

Show 1 - 3

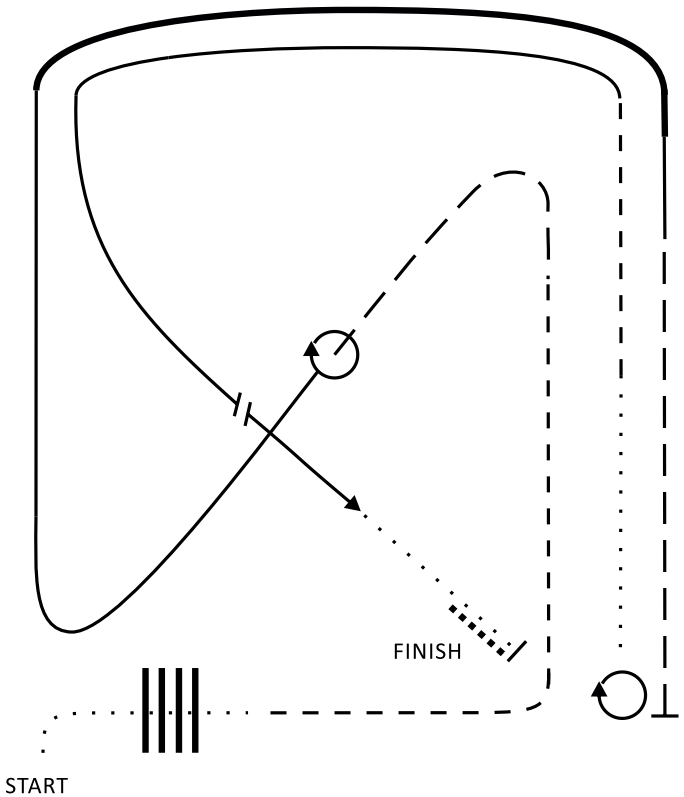

1. WALK AND WALK OVER LOGS.
2. JOG.
3. EXTENDED TROT.
4. STOP. 360° TURN TO THE RIGHT.
5. LOPE, RIGHT LEAD.
6. EXTENDED LOPE, COLLECT TO LOPE.
7. EXTENDED TROT.
8. STOP. 1 1/2 TURNS TO THE LEFT.
9. WALK.
10. JOG.
11. LOPE, LEFT LEAD.
12. CHANGE LEADS.
13. WALK, STOP AND BACK.

RANCH PLEASURE  
AMATEUR  
OPEN SENIOR  
AMATEUR SELECT

---

Show 4 - 6

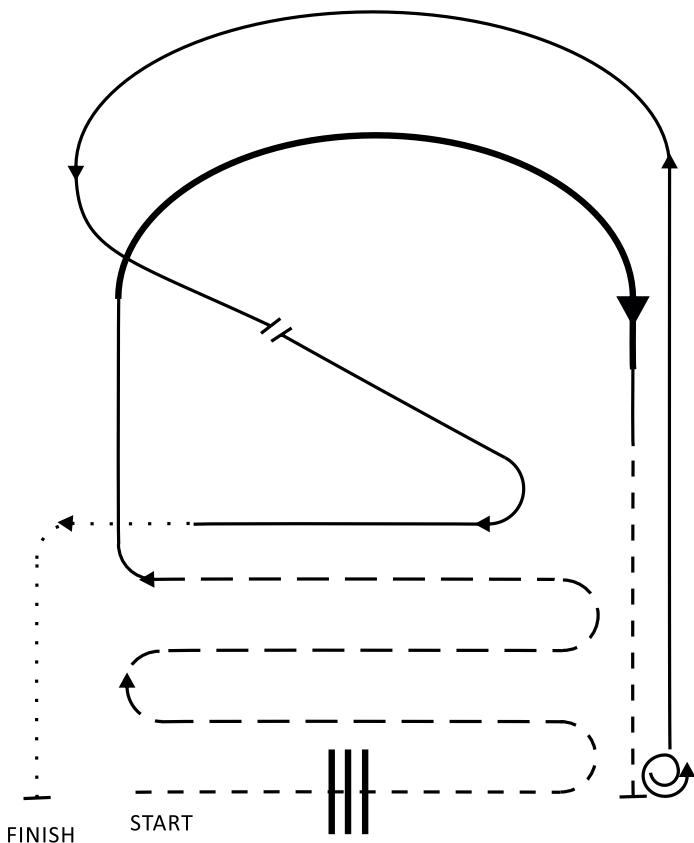

1. JOG OVER POLES
2. JOG.
3. EXTENDED TROT.
4. LOPE RIGHT LEAD.
5. EXTENDED LOPE, COLLECT TO LOPE.
6. JOG.
7. 1 1/2 TURNS TO THE LEFT.
8. LOPE LEFT LEAD.
9. CHANGE LEADS.
10. LOPE RIGHT LEAD.
11. WALK.
12. STOP AND BACK.

RANCH PLEASURE  
AMATEUR  
OPEN SENIOR  
AMATEUR SELECT

FINALS

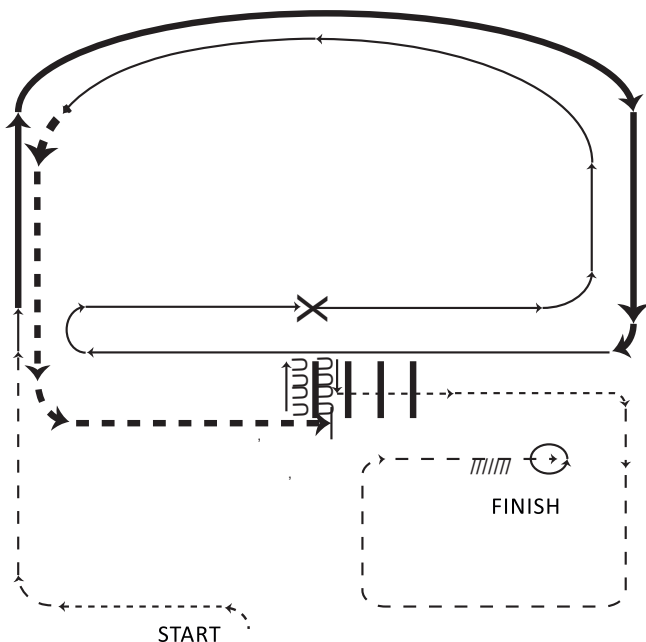

1. WALK.
2. JOG.
3. EXTENDED LOPE, RIGHT LEAD
4. LOPE, RIGHT LEAD.
5. CHANGE LEADS (SIMPLE OR FLYING)
6. LOPE LEFT LEAD.
7. EXTENDED TROT.
8. STOP, SIDE PASS LEFT, SIDE PASS RIGHT 1/2 WAY.
9. WALK OVER LOGS.
10. WALK.
11. TROT SQUARE.
12. STOP 360° TURN LEFT AND BACK.

# TRAIL

## NOVICE YOUTH - Show 1 - 3 NOVICE AMATEUR - Show 1 - 3

---

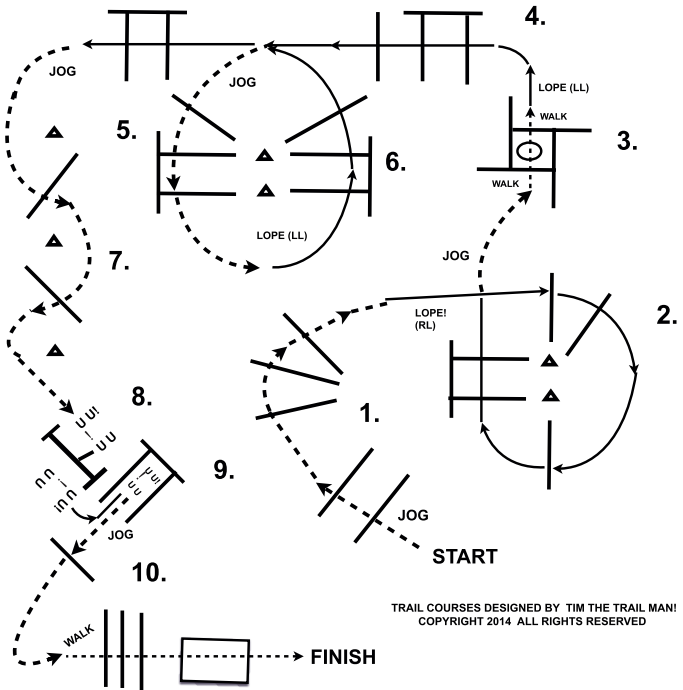

1. JOG OVER POLES
2. LOPE OVER POLES (RL).
3. BREAK TO JOG, THEN STOP OR BREAK TO WALK. WALK INTO BOX 360 EITHER WAY. WALK OUT BOX
4. LOPE OVER POLES (LL)
5. JOG OVER POLES
6. LOPE OVER POLES (LL)
7. JOG THRU SERPENTINE. JOG OVER POLES. JOG UP TO GATE
8. GATE, RH RIDE OVER POLE, CLOSE GATE
9. BACK THRU POLES, JOG OUT CHUTE
10. STOP OR BREAK TO A WALK. WALK OVER POLES AND BRIDGE

# TRAIL

AMATEUR - Show 1 - 3

OPEN JUNIOR - Show 1 - 3

AMATEUR SELECT - Show 1 - 3

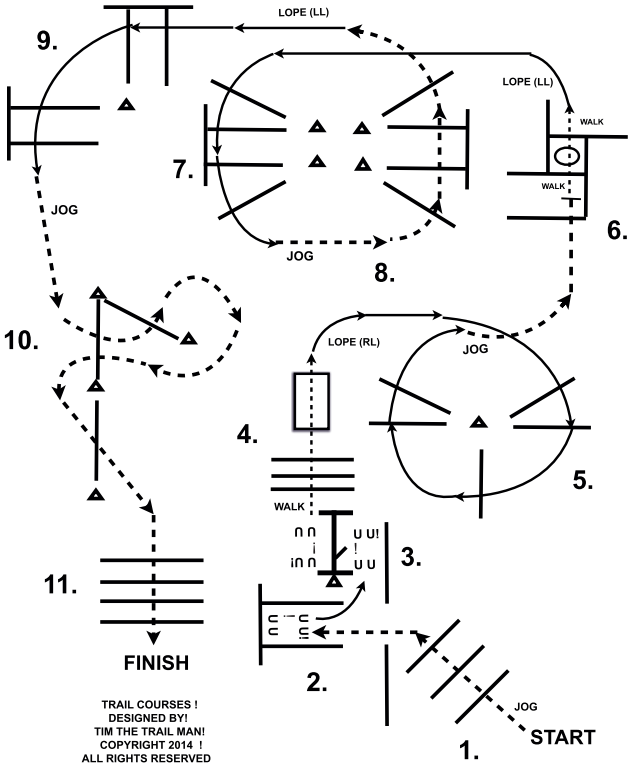

1. JOG OVER POLES. JOG INTO CHUTE
2. BACK THRU POLES. BACK UP TO GATE
3. GATE RH. RIDE THRU, CLOSE.
4. WALK OVER POLES AND OVER BRIDGE
5. LOPE OVER POLES (RL).
6. BREAK TO JOG, JOG OVER POLE, STOP. WALK INTO BOX. 360 EITHER WAY, WALK OUT.
7. LOPE OVER POLES (LL)
8. BREAK TO JOG, JOG OVER POLES.
9. LOPE OVER POLES (LL)
10. BREAK TO JOG. JOG THRU SERPENTINE. JOG OVER POLES.
11. JOG OVER POLES

# TRAIL

AMATEUR - Show 4 - 6

OPEN JUNIOR - Show 4 - 6

AMATEUR SELECT - Show 4 - 6

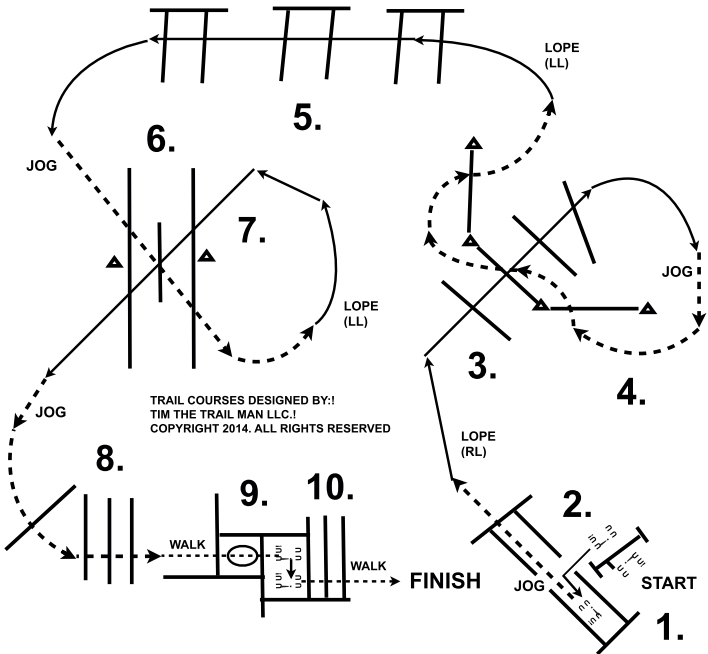

1. GATE: RIGHT HAND RIDE THRU CLOSE.
2. BACK THRU POLES, JOG OUT OVER POLE.
3. LOPE OVER POLES (RIGHT LEAD).
4. JOG THRU SERPENTINE, JOG OVER POLES.
5. LOPE OVER POLES (LEFT LEAD).
6. BREAK TO JOG, JOG OVER POLES.
7. LOPE OVER POLES (LEFT LEAD).
8. BREAK TO JOG, JOG OVER POLES.
9. STOP OR BREAK TO WALK, WALK INTO BOX, 360 EITHER WAY, WALK OUT BOX.
10. SIDE PASS RIGHT, WALK OVER POLES.



# TRAIL

## YOUTH 13 & UNDER - Show 1 - 3

## YOUTH 14 - 18 - Show 1 - 3

---

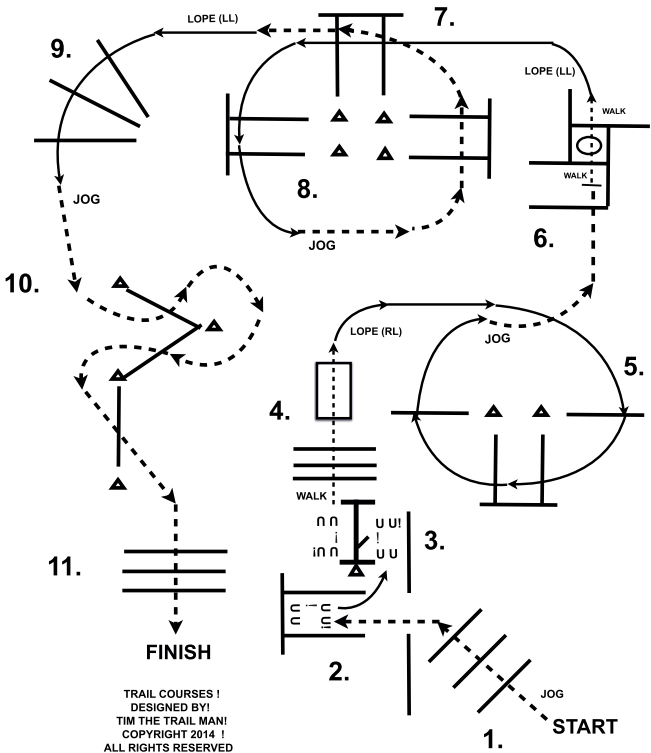

1. JOG OVER POLES. JOG INTO CHUTE
2. BACK THRU POLES. BACK UP TO GATE
3. GATE RH. RIDE THRU, CLOSE.
4. WALK OVER POLES AND OVER BRIDGE
5. LOPE OVER POLES (RL).
6. BREAK TO JOG, JOG OVER POLE, STOP. WALK INTO BOX. 360 EITHER WAY, WALK OUT.
7. LOPE OVER POLES (LL)
8. BREAK TO JOG, JOG OVER POLES.
9. LOPE OVER POLES (LL)
10. BREAK TO JOG. JOG THRU SERPENTINE. JOG OVER POLES.
11. JOG OVER POLES

# TRAIL

YOUTH 13 & UNDER - Show 4 - 6

YOUTH 14 - 18 - Show 4 - 6

---

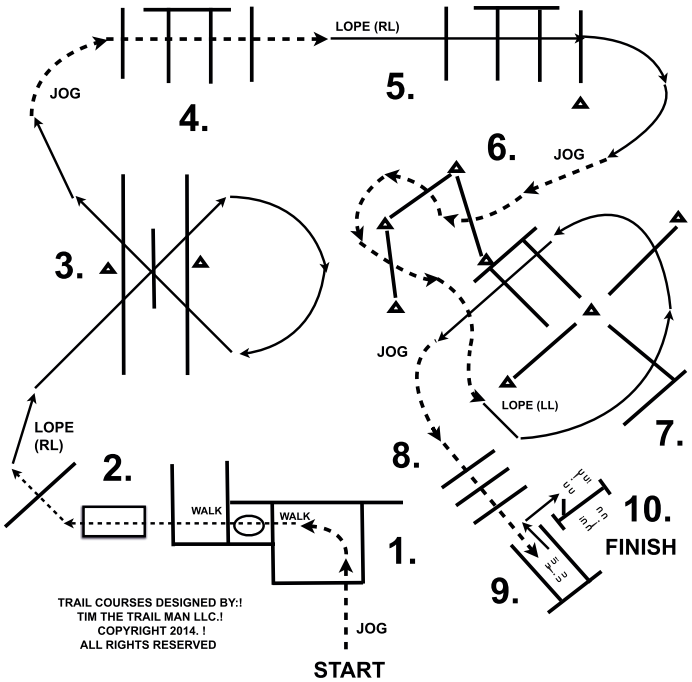

1. JOG OVER POLE, JOG UP TO BOX. STOP OR BREAK TO WALK. WALK INTO BOX, 360 TURN EITHER WAY, WALK OUT.
2. WALK OVER POLES AND OVER BRIDGE.
3. LOPE OVER POLES (RL).
4. BREAK TO JOG, JOG OVER POLES.
5. LOPE OVER POLES (RL).
6. BREAK TO JOG, JOG OVER POLES, JOG AROUND CONES.
7. LOPE OVER POLES (LL).
8. BREAK TO JOG, JOG OVER POLES.
9. JOG INTO CHUTE, BACK TO GATE.
10. GATE (LH), RIDE THRU, CLOSE.

# TRAIL GREEN - Show 1 - 3

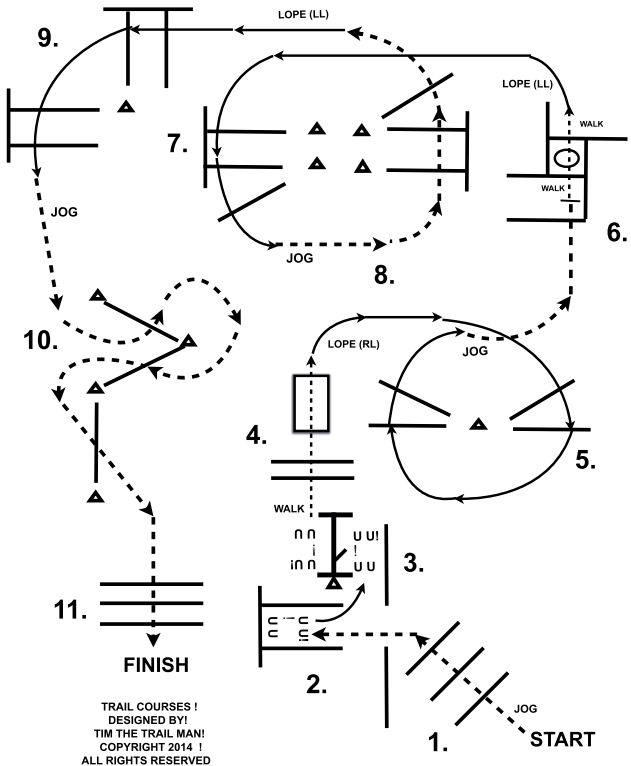

1. JOG OVER POLES. JOG INTO CHUTE
2. BACK THRU POLES. BACK UP TO GATE
3. GATE RH. RIDE THRU, CLOSE.
4. WALK OVER POLES AND OVER BRIDGE
5. LOPE OVER POLES (RL).
6. BREAK TO JOG, JOG OVER POLE, STOP. WALK INTO BOX. 360 EITHER WAY, WALK OUT.
7. LOPE OVER POLES (LL)
8. BREAK TO JOG, JOG OVER POLES.
9. LOPE OVER POLES (LL)
10. BREAK TO JOG. JOG THRU SERPENTINE. JOG OVER POLES.
11. JOG OVER POLES

# TRAIL GREEN - Show 4 - 6

---

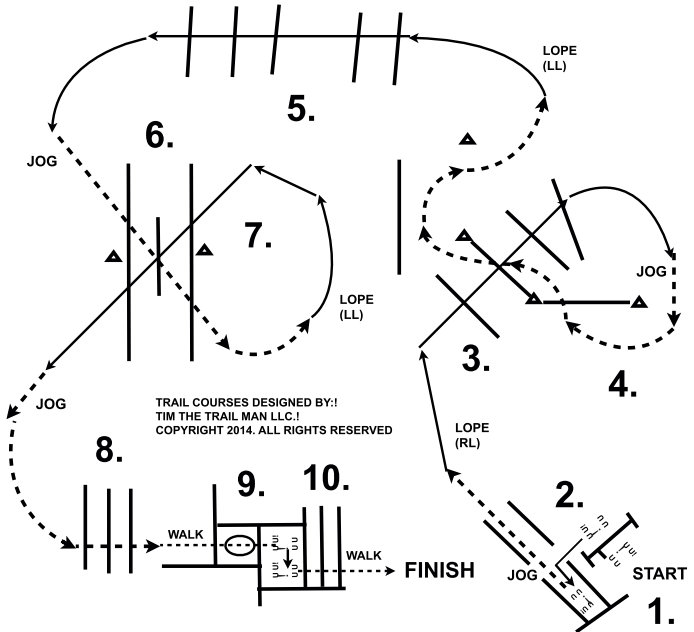

1. GATE: RIGHT HAND, RIDE THRU, CLOSE.
2. BACK THRU POLES, JOG OUT CHUTE.
3. LOPE OVER POLES (RIGHT LEAD)
4. JOG THRU SERPENTINE, JOG OVER POLES.
5. LOPE OVER POLES (LEFT LEAD)
6. BREAK TO JOG, JOG OVER POLES.
7. LOPE OVER POLES (LEFT LEAD).
8. BREAK TO JOG, JOG OVER POLES.
9. STOP OR BREAK TO WALK, WALK INTO BOX. 360 EITHER WAY, WALK OUT BOX.
10. SIDE PASS RIGHT, WALK OVER POLES.

# TRAIL

## OPEN SENIOR - Show 1 - 3

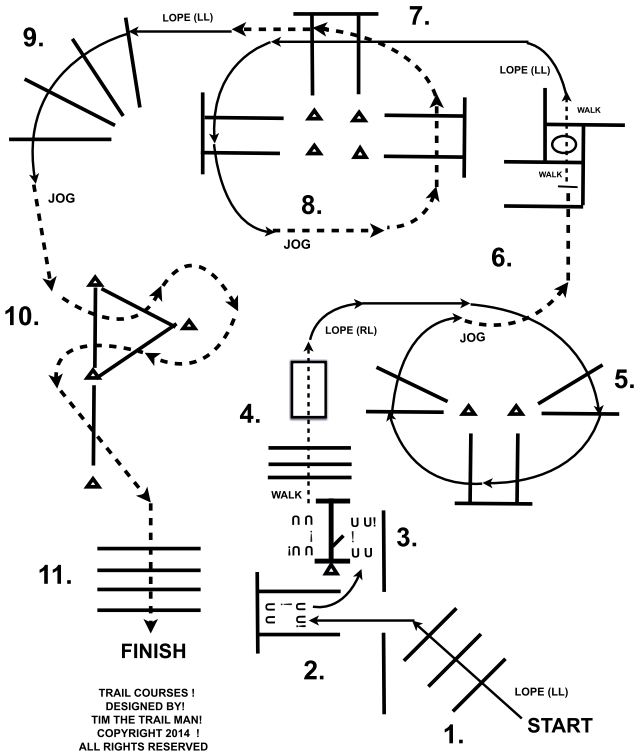

1. LOPE OVER POLES (LL). LOPE INTO CHUTE
2. BACK THRU POLES. BACK UP TO GATE
3. GATE RH. RIDE THRU, CLOSE.
4. WALK OVER POLES AND OVER BRIDGE
5. LOPE OVER POLES (RL).
6. BREAK TO JOG, JOG OVER POLE, STOP. WALK INTO BOX. 360 EITHER WAY, WALK OUT.
7. LOPE OVER POLES (LL)
8. BREAK TO JOG, JOG OVER POLES.
9. LOPE OVER POLES (LL)
10. BREAK TO JOG. JOG THRU SERPENTINE. JOG OVER POLES.
11. JOG OVER POLES

# TRAIL

## OPEN SENIOR - Show 4 - 6

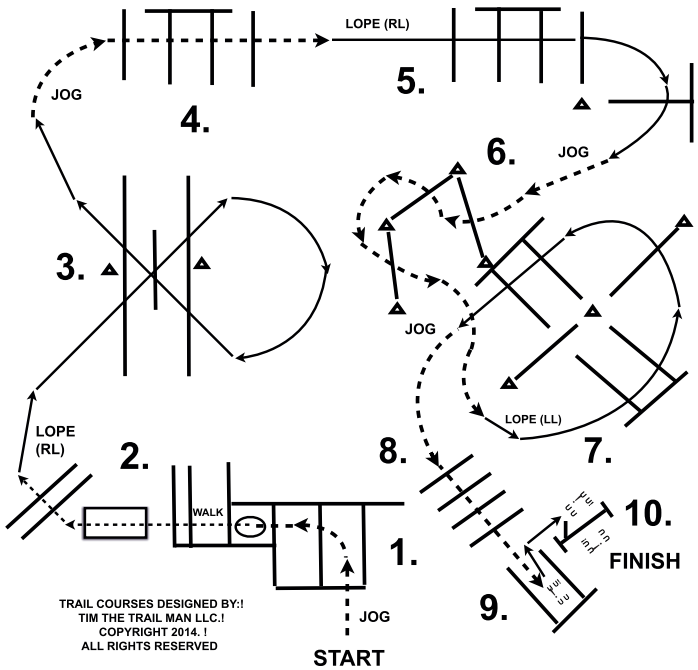

1. JOG OVER POLES, JOG INTO BOX. 360 TURN EITHER WAY, WALK OUT BOX.
2. WALK OVER POLES AND OVER BRIDGE.
3. LOPE OVER POLES (RL).
4. BREAK TO JOG, JOG OVER POLES.
5. LOPE OVER POLES (RL).
6. BREAK TO JOG, JOG OVER POLES, JOG AROUND CONES.
7. LOPE OVER POLES (LL).
8. BREAK TO JOG, JOG OVER POLES.
9. JOG INTO CHUTE, BACK TO GATE.
10. GATE (LH) RIDE THRU CLOSE.

# TRAIL OPEN JUNIOR YOUTH 13 & UNDER

## FINALS

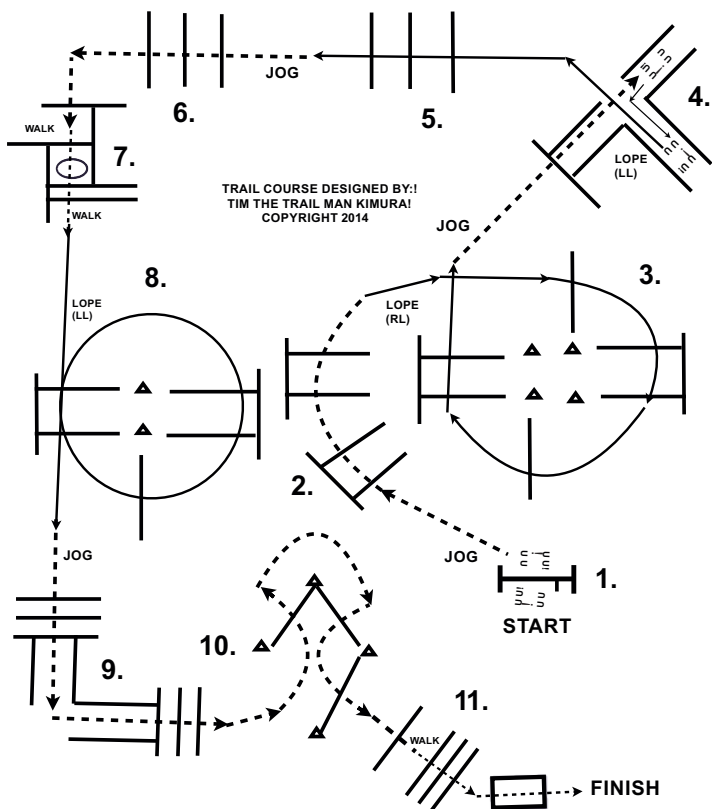

1. GATE LH OPEN, WALK OVER POLE, CLOSE GATE
2. JOG OVER POLES.
3. LOPE OVER POLES (RL).
4. BREAK TO JOG, JOG INTO CHUTE, BACK THRU POLES, LOPE OUT (LL).
5. LOPE OVER POLES (LL).
6. BREAK TO JOG, JOG OVER POLES AND STOP IN SPACE BEFORE BOX.
7. WALK INTO BOX, EXECUTE A 360 TURN EITHER WAY, WALK OUT OVER POLES.
8. LOPE OVER POLES (LL).
9. BREAK TO JOG, JOG OVER POLES.
10. JOG OVER POLES, JOG AROUND CONES.
11. JOG OVER POLE, STOP, WALK OVER POLES AND OVER BRIDGE.

# TRAIL AMATEUR SELECT

## FINALS

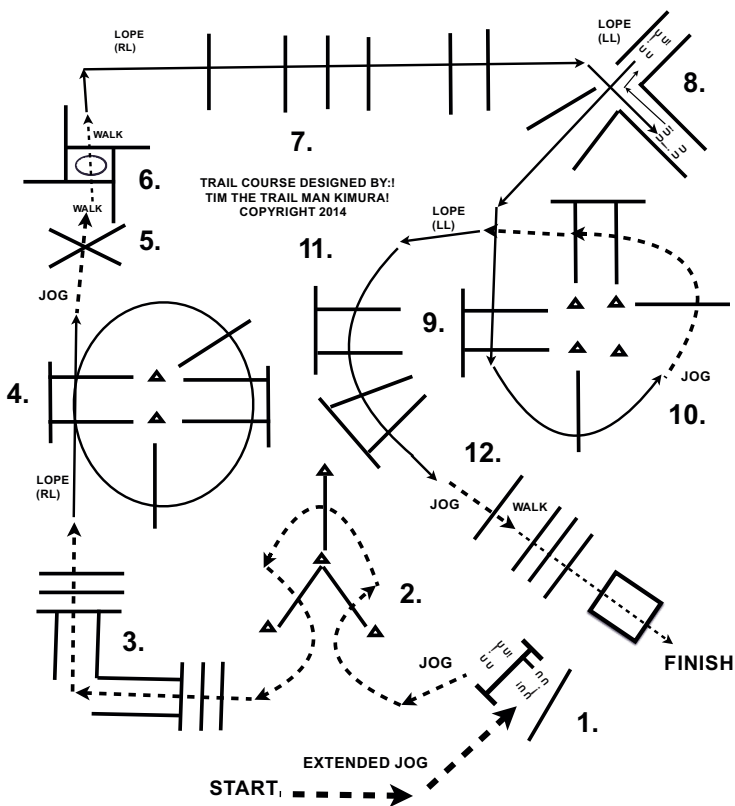

1. EXTEND THE JOG UP TO GATE: GATE LH OPEN, WALK OVER POLE, CLOSE GATE.
2. JOG OVER POLES AND AROUND CONES.
3. JOG OVER POLES
4. LOPE OVER POLES (RL).
5. BREAK TO JOG, JOG OVER X AND STOP.
6. WALK INTO BOX, EXECUTE A 360 TURN IN BOX, WALK OUT BOX, WALK OVER POLE.
7. LOPE OVER POLES (RL).
8. LOPE INTO CHUTE (RL), BACK THRU POLES, LOPE OUT (LL).
9. LOPE OVER POLES (LEFT LEAD).
10. BREAK TO JOG, JOG OVER POLES.
11. LOPE OVER POLES (LL).
12. BREAK TO THE JOG, JOG OVER POLE, STOP IN GAP, WALK OVER POLES AND OVER BRIDGE



# TRAIL AMATEUR YOUTH 14 - 18

## FINALS

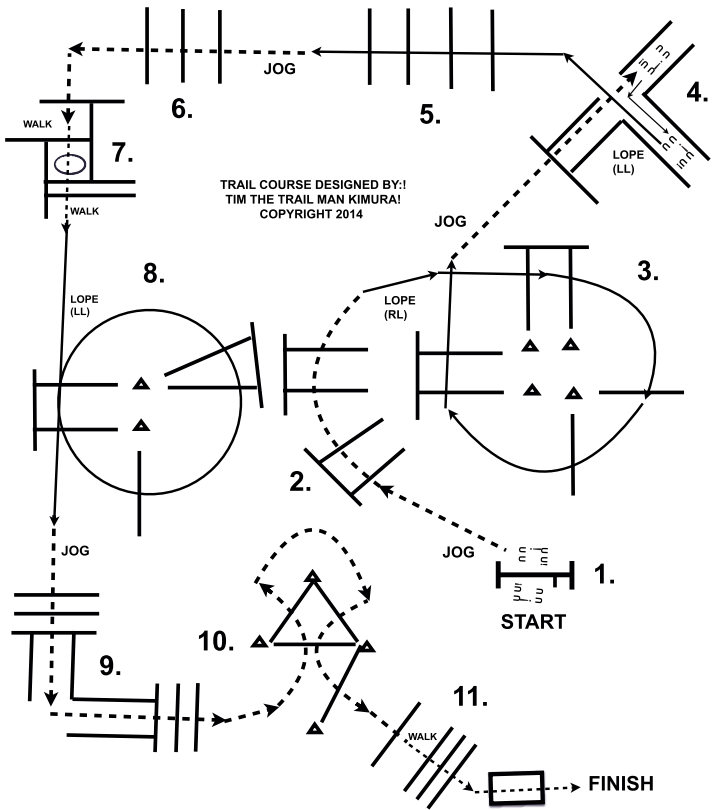

1. GATE LH OPEN, WALK OVER POLE, CLOSE GATE.
2. JOG OVER POLES.
3. LOPE OVER POLES. (RL).
4. BREAK TO JOG, JOG INTO CHUTE, BACK THRU POLES, LOPE OUT (LL).
5. LOPE OVER POLES (LL).
6. BREAK TO JOG, JOG OVER POLES AND STOP IN SPACE BEFORE BOX.
7. WALK INTO BOX, EXECUTE A 360 TURN EITHER WAY, WALK OUT OVER POLES.
8. LOPE OVER POLES (LL).
9. BREAK TO JOG, JOG OVER POLES.
10. JOG OVER POLES, JOG AROUND CONES.
11. JOG OVER POLE, STOP, WALK OVER POLES AND OVER BRIDGE.

# TRAIL OPEN SENIOR

## FINALS

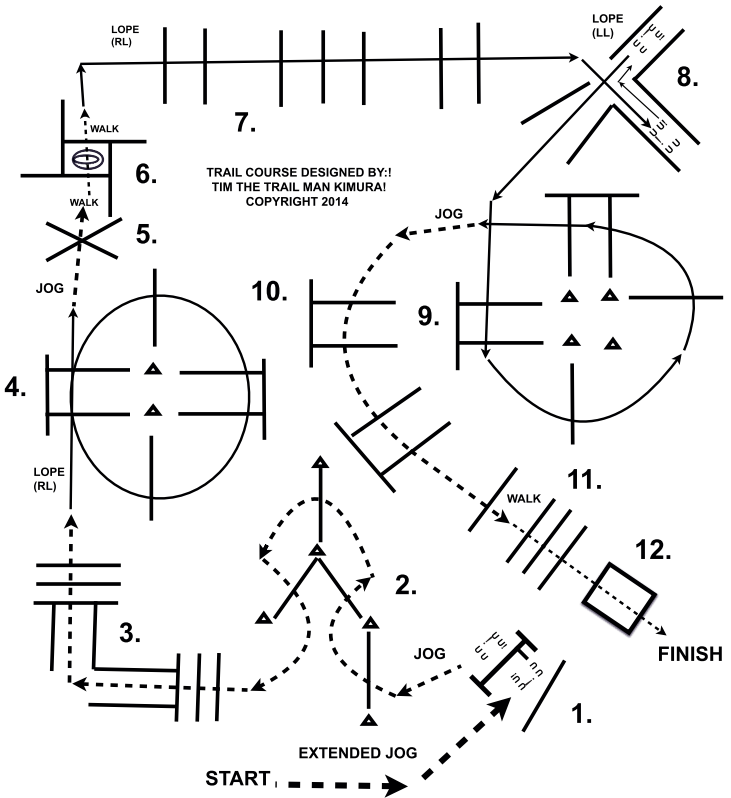

1. EXTEND THE JOG UP TO GATE. GATE LH OPEN, WALK OVER POLE, CLOSE GATE.
2. JOG OVER POLES AND AROUND CONES.
3. JOG OVER POLES.
4. LOPE OVER POLES (RL).
5. BREAK TO JOG, JOG OVER X AND STOP.
6. WALK INTO BOX, EXECUTE 2 360 TURNS IN BOX, WALK OUT BOX, WALK OVER POLE.
7. LOPE OVER POLES (RL).
8. LOPE INTO CHUTE (RL), BACK THRU POLES, LOPE OUT (LL).
9. LOPE OVER POLES. (LEFT LEAD).
10. BREAK TO JOG, JOG OVER POLES.
11. JOG OVER POLE, STOP IN GAP, WALK OVER POLES.
12. WALK OVER BRIDGE.



# CC SHOWHORSES

*... we breed for Pleasure!*

DQHA HALL OF FAME  
DQHA UND NSBA LEADING BREEDER  
DQHA LEADING DAM

[WWW.CC-SHOWHORSES.DE](http://WWW.CC-SHOWHORSES.DE)

FEQHA  
FEDERATION  
OF  
EUROPEAN  
QUARTER  
HORSE  
ASSOCIATIONS



THANK YOU FOR JOINING THE

